

*All DC Inverter VRF Outdoor Unit*

---

# INSTALLATION MANUAL

- Thank you very much for purchasing our air conditioner!
- This instruction manual is the universal version for ALL DC Inverter VRF air conditioners, the appearance of your air conditioner may be varying with the appearance of unit introduced in the manual, but it will not confuse you in operating and using.
- Please read this manual carefully before using, and keep it for future reference.
- To protect your lawful rights and interests, your air conditioner must be installed by a professional worker.



# Contents

---

|   |    |
|---|----|
| 1. Safety precautionary measure .....         | 1  |
| 2. Key points in installation inspection..... | 2  |
| 3. Installation of outdoor unit .....         | 3  |
| 4. Design of refrigerant pipes .....          | 11 |
| 5. Electrical wiring .....                    | 19 |
| 6. Trial running .....                        | 27 |

# 1. Safety precautionary measure

---

## **WARNING**

1. This air conditioner is a comforting unit which cannot be used in any special place for storing machines, precise instruments, food, plants, poultries or artworks, etc.
2. The installation work must be done by the distributor or a professional worker.
3. The installation worker must be equipped with all related knowledge as a wrong operation may cause fire risk, electric shock, injury or water leakage, etc.
4. If the unit is to be installed in a small room, suitable measures shall be taken to make sure any refrigerant leakage concentration if happened in the room will not exceed the critical level.
5. For detailed measures, please consult with the distributor.
6. Connection of power supply must be complying with rules specified by the local electrical authority.
7. If the air conditioner is to be moved or reinstalled, please let the distributor or a professional worker operate. Incorrect installation will cause fire risk, electric shock, injury or water leakage, etc.
8. The user is not permitted to rebuild or repair the unit of own accord. Incorrect repairing will cause fire risk, electric shock, injury or water leakage, etc, so repairing must be performed by the distributor or a professional worker.
9. The A-weighted sound pressure level is below 70dB.
10. This appliance is intended to be used by expert or trained users in shops, in light industry and on farms, or for commercial use by lay persons.
11. The appliance shall be disconnected from its power source during service and when replacing parts and, if that the removal of the plug is foreseen, it shall be clearly indicated that the removal of the plug has to be such that an operator can check from any of the points to which he has access that the plug remains removed.
12. The appliance shall be maintained by the professional every three years.

## **NOTICE**

1. Make sure the water drainage ditch is useable.
2. Make sure a current leakage protection switch is equipped.
3. The current leakage protection switch must be equipped or there may be an electric shock.
4. It mustn't be installed in any position with potential leakage of inflammable gas.
5. If any inflammable gas leaks, there may be a fire risk around the indoor unit.
6. Make sure the foundation installation or suspending installation is firm and reliable.
7. If the foundation or suspension is not firm and reliable enough, there may be a fall accident.
8. Make sure all electric cables are correctly connected.
9. If any electric cable is incorrectly connected, any electrical part may be damaged.
10. If the refrigerant leaks during installation, the room must be ventilated at once.
11. The leaked refrigerant may generate some toxic gas if it contacts any flame.
12. After installation, make sure there is no refrigerant leakage.
13. If the refrigerant gas enters and contacts some flame source such as a heater, a stove or an electric cooker, it may generate some toxic gas.
14. A lightning protection device must be equipped as per the applicable national regulation, or the machine may be damaged by a lightning strike.

## **NOTICE**

1. The products are not to be connected to public low voltage a.c distribution systems.
2. The appliance shall be installed in accordance with national wiring regulations.
3. Stationary appliances not fitted with means for disconnection from the supply mains having a contact separation in all poles that provide full disconnection under overvoltage category III, the instructions state that means for disconnection must be incorporated in the fixed wiring in accordance with the wiring rules.
4. If the supply cord is damaged, it must be replaced by the manufacturer, its service agent or similarly qualified persons in order to avoid a hazard.
5. This appliance can be used by children aged from 8 years and above and persons with reduced physical, sensory or mental capabilities or lack of experience and knowledge if they have been given supervision or instruction concerning use of the appliance in a safe way and understand the hazards involved.
6. Children shall not play with the appliance.
7. Cleaning and user maintenance shall not be made by children without supervision.
8. GWP:R410A:2087.5.
9. Disconnect the power supply before cleaning and maintenance.



## 2. Key points in installation inspection

---

### 2-1 Receival and unpacking inspection

- 1) When the machine is received, check if there is any damage in transportation. If any surface or internal damage is found, please inform the transportation agency in a written form.
- 2) After the machine is received, check if the device type, specification and quantity are complying with the contract.
- 3) When unpacking the product, please well keep the instruction manual and check all accessories.

### 2-2 Refrigerant tube

- 1) The refrigerant tube installation must be performed by the special refrigerant dispenser (separately ordered) for the manufacturer central air conditioner.
- 2) The refrigerant tube must be of the specified tube diameter and tube wall thickness.
- 3) Copper tube welding must be performed with nitrogen filled protection, and the tube must be filled with nitrogen gas of 0.02MPa which cannot be cut off until welding is completed and the copper tube is thoroughly cooled down.
- 4) The refrigerant tube must be treated with thermal insulation.
- 5) After the refrigerant tube is installed and before gas tightness test and vacuumization, the indoor unit cannot be electrified.

### 2-3 Gas tightness test

After the refrigerant tube is installed, nitrogen gas of 40kgf/cm<sup>2</sup> (4.0MPa) must be filled from the gas side and liquid side at the same time for 24-hour gas tightness test.

### 2-4 Vacuumizations

After the air tightness test, vacuumization (vacuum degree -0.1MPa) must be performed from both the gas side and the liquid side at the same time.

### 2-5 Refrigerant refilling

- 1) The volume of refrigerant to be refilled is calculated on the diameter and length (actual length) of the tubes at the outdoor unit and indoor unit liquid side.
- 2) The volume of refrigerant to be refilled, liquid tube diameter, tube length and height difference between the outdoor unit and indoor unit shall be recorded on the confirmation table (on the cover of the electrical box) for future reference.

### 2-6 Electrical wiring

- 1) The selection of power supply capacity and wire diameter shall be complying with the design manual. The diameter of power supply cable for an air conditioner is usually larger than the diameter of motor cable.
- 2) To prevent any disoperation of the air conditioner, the power supply cable (380-415V 3N ~) can not be twisted with any connecting cable of outdoor unit and indoor unit (low voltage cable).
- 3) The indoor unit can be electrified after gas tightness test and vacuumization.
- 4) The location of outdoor unit must be set, as shown in Chapter 5.4, and the SW6 dialing code must be set within 0~3, in which, 0# is the dominating unit and others are dominated units.

### 2-7 Trial run ning

- 1) The two pieces of pearl cotton protecting the condenser at the back of the unit shall be removed before trial running. They must be taken out carefully so as not to damage the fins or the performance of thermal exchange will be influenced.
- 2) Trial running cannot be started unless the outdoor unit is electrified and preheated for more than 12h, or the system may be damaged.

### 3. Installation of outdoor unit

#### 3-1 Combination mode of outdoor units

Tab3.1 Combination mode of outdoor units

| Outdoor unit HP | Combination mode 1 | Combination mode 2 | Max No. of indoor units (sets) | Recommended No. of indoor units(sets) |
|-----------------|--------------------|--------------------|--------------------------------|---------------------------------------|
| 8               | 8HP                | 8HP                | 13                             | 7                                     |
| 10              | 10HP               | 10HP               | 16                             | 9                                     |
| 12              | 12HP               | 12HP               | 19                             | 11                                    |
| 14              | 14HP               | 14HP               | 23                             | 13                                    |
| 16              | 16HP               | 16HP               | 26                             | 15                                    |
| 18              | 18HP               | 18HP               | 29                             | 16                                    |
| 20              | 20HP               | 20HP               | 33                             | 18                                    |
| 22              | 22HP               | 22HP               | 36                             | 20                                    |
| 24              | 24HP               | 24HP               | 39                             | 22                                    |
| 26              | 26HP               | 10HP+16HP          | 43                             | 24                                    |
| 28              | 28HP               | 10HP+18HP          | 46                             | 26                                    |
| 30              | 30HP               | 12HP+18HP          | 50                             | 27                                    |
| 32              | 32HP               | 10HP+22HP          | 53                             | 29                                    |
| 34              | 16HP+18HP          | 16HP+18HP          | 56                             | 31                                    |
| 36              | 18HP+18HP          | 18HP+18HP          | 59                             | 32                                    |
| 38              | 16HP+22HP          | 16HP+22HP          | 63                             | 35                                    |
| 40              | 18HP+22HP          | 18HP+22HP          | 64                             | 36                                    |
| 42              | 20HP+22HP          | 20HP+22HP          | 64                             | 38                                    |
| 44              | 22HP×2             | 22HP×2             | 64                             | 38                                    |
| 46              | 22HP+24HP          | 22HP+24HP          | 64                             | 38                                    |
| 48              | 24HP×2             | 24HP×2             | 64                             | 38                                    |
| 50              | 22HP+28HP          | 12HP+16HP+22HP     | 64                             | 38                                    |
| 52              | 24HP+28HP          | 12HP+18HP+22HP     | 64                             | 38                                    |
| 54              | 24HP+30HP          | 10HP+22HP×2        | 64                             | 38                                    |
| 56              | 24HP+32HP          | 12HP+22HP×2        | 64                             | 40                                    |
| 58              | 26HP+32HP          | 14HP+22HP×2        | 64                             | 40                                    |
| 60              | 28HP+32HP          | 16HP+22HP×2        | 64                             | 40                                    |
| 62              | 30HP+32HP          | 18HP+22HP×2        | 64                             | 40                                    |
| 64              | 32HP×2             | 20HP+22HP×2        | 64                             | 40                                    |
| 66              | 22HP×2             | 22HP×2             | 64                             | 40                                    |
| 68              | 22HP×2+24HP        | 12HP×2+22HP×2      | 64                             | 44                                    |
| 70              | 22HP+24HP×2        | 10HP+16HP+22HP×2   | 64                             | 44                                    |
| 72              | 22HP×2+28HP        | 12HP+16HP+22HP×2   | 64                             | 44                                    |
| 74              | 18HP+28HP×2        | 12HP+18HP+22HP×2   | 64                             | 44                                    |
| 76              | 24HP×2+28HP        | 10HP+22HP×3        | 64                             | 44                                    |
| 78              | 22HP+28HP×2        | 12HP+22HP×3        | 64                             | 48                                    |
| 80              | 24HP+28HP×2        | 14HP+22HP×3        | 64                             | 48                                    |
| 82              | 26HP+28HP×2        | 16HP+22HP×3        | 64                             | 48                                    |
| 84              | 28HP×3             | 18HP+22HP×3        | 64                             | 48                                    |
| 86              | 28HP×2+30HP        | 20HP+22HP×3        | 64                             | 48                                    |
| 88              | 28HP×2+32HP        | 22HP×4             | 64                             | 48                                    |
| 90              | 26HP+32HP×2        | 22HP×3+24HP        | 64                             | 48                                    |
| 92              | 28HP+32HP×2        | 22HP×2+24HP×2      | 64                             | 48                                    |
| 94              | 30HP+32HP×2        | 22HP+24HP×3        | 64                             | 48                                    |
| 96              | 32HP×3             | 24HP×4             | 64                             | 48                                    |

Remark:

1. For combination 1, outdoor unit joint refer to 3 units combination.
2. For combination 2, outdoor unit joint refer to 4 units combination.

## 3. Installation of outdoor unit



### WARNING

1. The air conditioner must be installed in a place of enough strength to support the machine weight.
2. If it lacks of strength, the machine may fall down and cause some personal injury.
3. The installation must be performed specially to prevent strong wind or earthquake.
4. Incorrect installation may cause some accident because of machine falling down.

### 3-2 Selection of installation position

- 1) Enough space for installation and maintenance;
- 2) No barrier at the inlet and outlet air ports and away from strong wind;
- 3) Dry and ventilating;
- 4) The flat supporting platform has enough capacity to carrying the outdoor unit weight which can be horizontally installed without increasing any noise or vibration;
- 5) Neighbors not influenced by operating noise and exhaust gas;
- 6) No leakage of inflammable gas;
- 7) Convenient for tube connection and electrical connection.
- 8) Avoid installing in places with high salinity or corrosive gas, etc. If unavoidable, choose anti-corrosion model.

### 3-3 Drawing of outdoor unit dimensions (unit: mm)

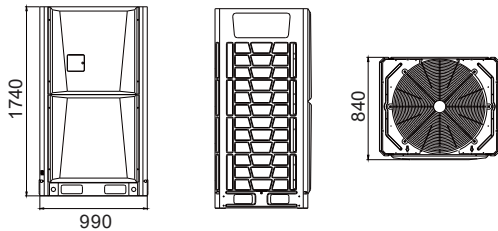

Fig. 3.1 Shape1 (8HP~12HP)

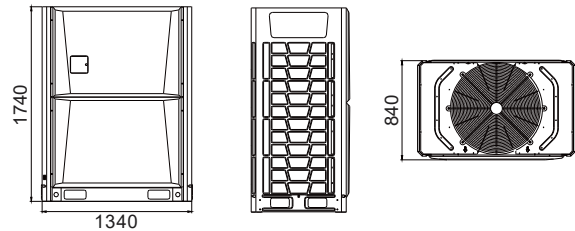

Fig. 3.2 Shape2 (14HP~16HP)

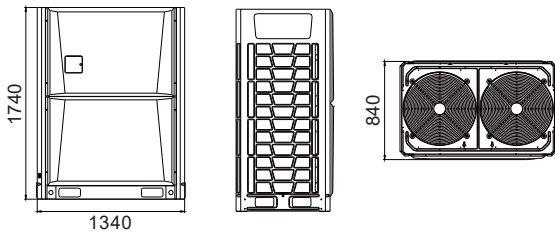

Fig. 3.3 Shape3 (18HP~20HP)

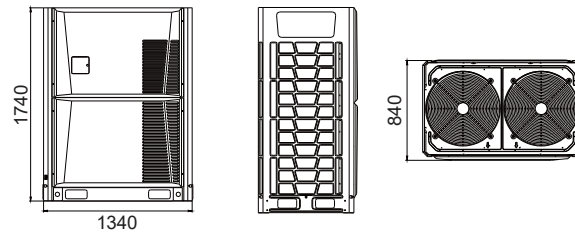

Fig. 3.4 Shape4 (22HP)

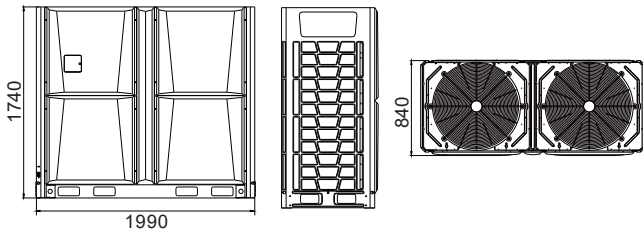

Fig. 3.5 Shape5 (24HP)

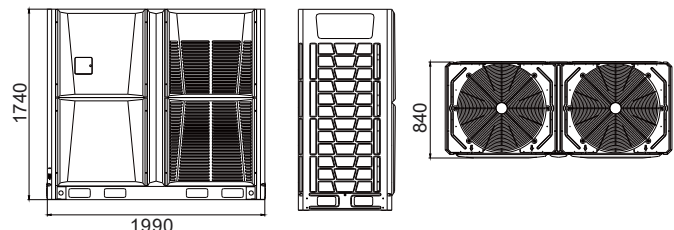

Fig. 3.6 Shape6 (26HP~32HP)

### 3-4 Hoisting of outdoor unit

- 1) No packing material can be removed during hoisting, hoisting shall be made by two ropes of 8m above bound on the package, and the machine must be balanced and hoisted safely and reliably. If there is no package or the packing material is broken, some backing board or packing material shall be used for protection.
- 2) The outdoor material shall be handled and hoisted vertically within 15°, and safety is the most important during handling and hoisting.

# 3. Installation of outdoor unit

## 3-5 Foundation for outdoor unit

### 1. Provide a firm and adequate foundation to:

- 1) Protect the outdoor machine from sinking;
- 2) Prevent any abnormal noise cause by the foundation.

### 2. Foundation type

- 1) Steel structure
- 2) Concrete structure (shown as the figure below)

### 3. Key points in foundation construction:

- 1) The master machine shall be installed on a firm cement ground or concrete foundation. The concrete foundation is constructed as per Fig. 3.3, or be constructed with field measuring.
- 2) The foundation must be fully leveled to ensure all points are uniformly contacted.
- 3) The foundation shall be constructed to ensure it directly supports the vertical edges of the front and back base plates which are the actual weight bearing positions of the machine.
- 4) When the foundation is set on the roof, no crushed stone bed is required, but the concrete surface must be roughened. The standard concrete mixture ratio is: cement 1/ sand 2/ gravel 4, and reinforced by steel bar of  $\Phi 10$ . The cement mortar surface must be leveled and the foundation edge shall be chamfered.
- 5) The foundation shall be set with drainage ditches around to avoid water accumulation.
- 6) Make sure the roof has enough bearing capacity.
- 7) For tube connection at the unit bottom, the foundation shall be at least 200mm below the unit.

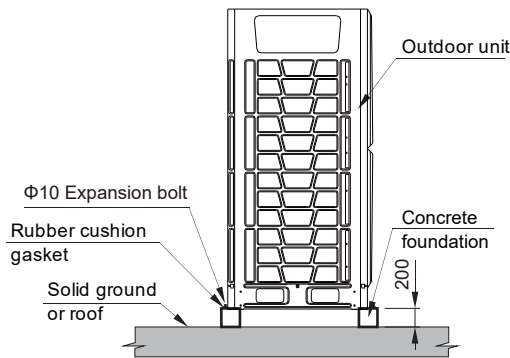

Fig. 3.7 Foundation

## 3-6 Drawing of positions for installation of anchor bolts

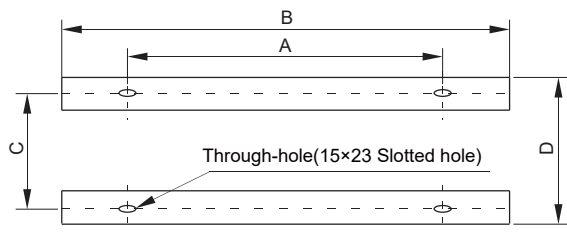

Fig. 3.8 bolts location

Tab.3.2 bolts location

| Size | Type | 8HP~12HP | 14HP~22HP | 24HP~32HP |
|------|------|----------|-----------|-----------|
| A    |      | 720mm    | 1070mm    | 1720mm    |
| B    |      | 1040mm   | 1390mm    | 2060mm    |
| C    |      | 774mm    | 774mm     | 774mm     |
| D    |      | 850mm    | 850mm     | 850mm     |

## 3-7 Drawing of center for each connecting tube

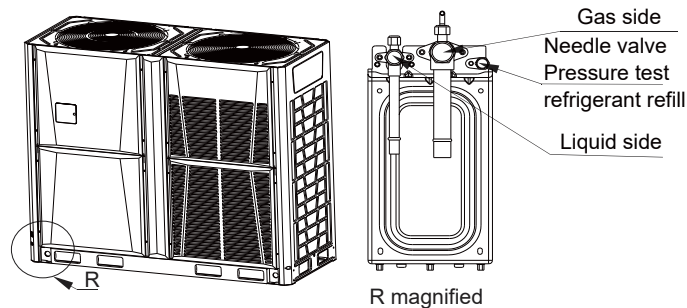

Fig. 3.9 Connecting tubes

## 3. Installation of outdoor unit

### 3-8 Key points for installation of outdoor unit

- 1) Vibration isolators or vibration isolating pads shall be installed between the unit and foundation as per the design specification.
- 2) The outdoor unit must be tightly contacted with the foundation to avoid excessive vibration and noise.
- 3) An earth line must be connected as per legal rules.
- 4) Before debugging, the valves on the gas and liquid tubes of the outdoor unit cannot be opened.
- 5) The installation position must be with enough space or maintenance.

### 3-9 Arrangement sequence outdoor units and setting of master and slave units

When a system is equipped with more than two outdoor units, the following mode is recommended for setting: outdoor units are arranged by sizes, and the largest one is set at the 1st manifold; the outdoor unit with the largest power is set as the master unit, and others are slaves. For example there is a system of 80HP (a combination of 32HP, 24HP and 24HP):

- 1) The unit of 32HP is set at the 1st manifold (see Fig. 3.10).
- 2) The arranging sequence is 32HP, 24HP and then 24HP.
- 3) The unit of 32HP is set as the master unit, and units 24HP and 24HP are the slave.

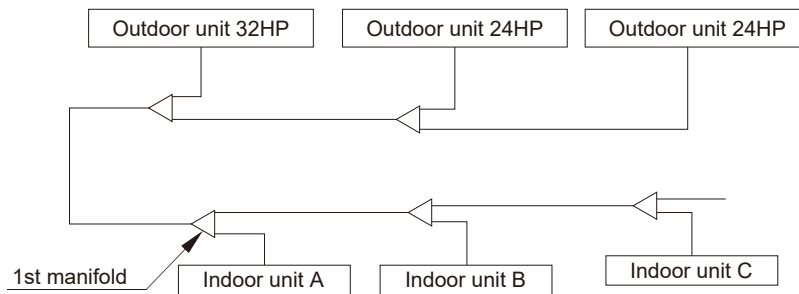

Fig. 3.10 Sequence of outdoor unit

### 3-10 Installation space of outdoor unit

- 1) When installation, a maintenance space as shown in Fig. 3.11 shall be left, the power supply device shall be installed at the side of the outdoor unit as per the method shown in the installation manual for the power supply unit.
- 2) Make sure there is necessary space for installation and maintenance, and modules in a system must be arranged at the same height.
- 3) When outdoor units are higher than surrounding barriers and they will be arranged in a row, please see Fig. 3.12.
- 4) When outdoor units are higher than surrounding barriers and they will be arranged in 2 rows, please see Fig. 3.13.
- 5) When outdoor units are higher than surrounding barriers and they will be arranged in more than 2 rows, please see Fig. 3.14.
- 6) When outdoor units are lower than surrounding barriers, please see Fig. 3.15; the arrangement is similar with the situation when outdoor units are higher than surrounding barriers, but to prevent the thermal exchange effect is influenced by outdoor hot air, a wind scooper shall be equipped to radiating cover of the outdoor unit, as shown in Fig. 3.15. The height of wind scooper is H-h, and the scooper shall be made by the user in the field.
- 7) When there is any barrier above the outdoor unit, please see Fig. 3.16.

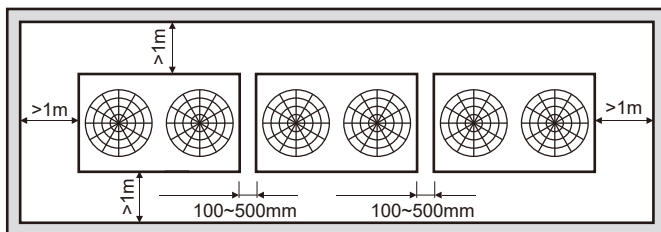

Fig. 3.11 Installation space of outdoor unit

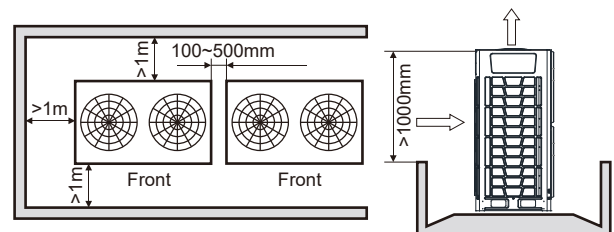

Fig. 3.12 1 row

### 3. Installation of outdoor unit

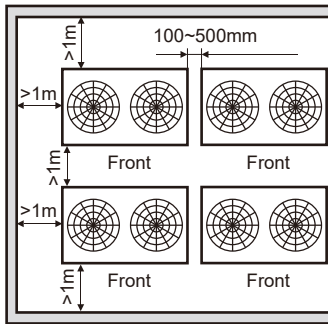

Fig. 3.13 2 rows

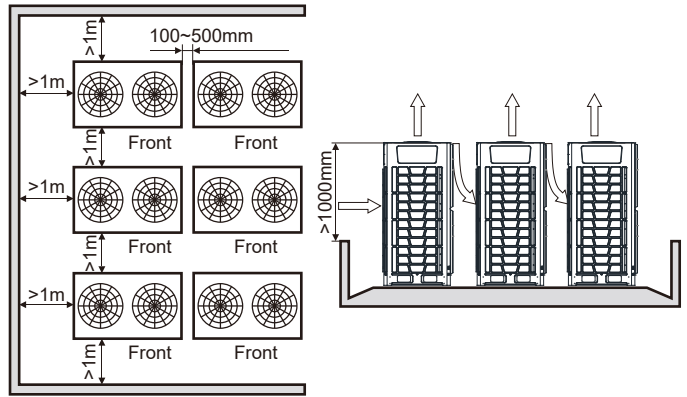

Fig. 3.14 More than 2 rows

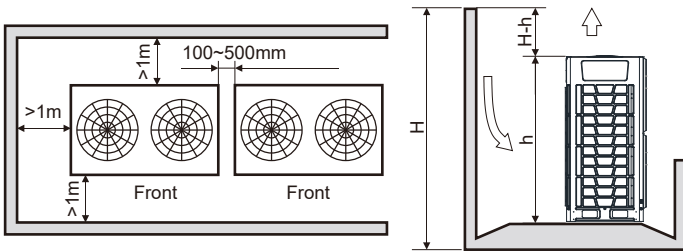
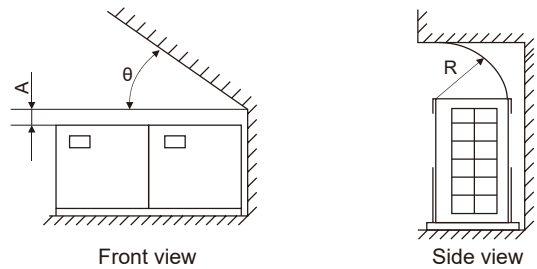

Fig. 3.15 Lower than surrounding barriers



| Size  | A(mm) | R(mm)  | $\theta(^{\circ})$ |
|-------|-------|--------|--------------------|
| Value | A>300 | R>1000 | $\theta>45$        |

Fig. 3.16 Barrier above outdoor unit

#### ! NOTICE

1. If there is material stacked around the outdoor unit, the stack height (H-h) must be 800mm below the top of the outdoor unit. If the height is lower than the specified size, a mechanical ventilating device must be attached.

#### 3-11 Snow-drift control device

A snow-drift control device must be installed in snowing area (see the figure at right, as some failure may be happen if there is no completed snow control system). To avoid snow accumulation, a high support must be set for installing snow sheds at the air inlet and air outlet. See Fig. 3.17.

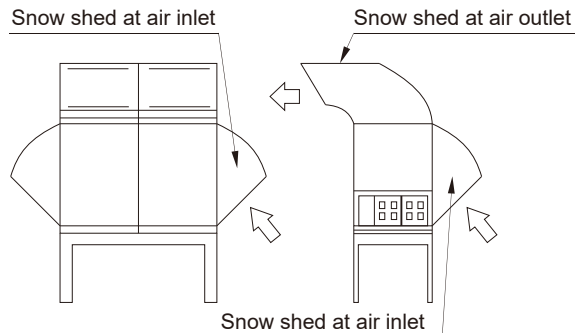

Fig. 3.17 Snow-drift control device

#### 3-12 Installation of outdoor unit wind scooper

The wind scooper is provided in field installation, and when installing, the screen shield shall be removed, and then the wind scooper can be installed as per the following two plans.

### 3. Installation of outdoor unit

#### 1) 8HP~12HP

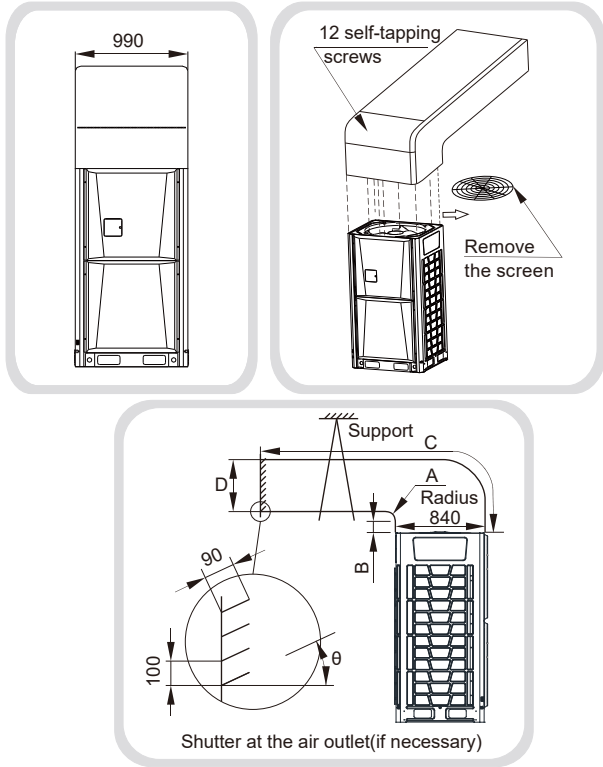

| Size  | A(mm)        | B(mm)        | C(mm)         | D(mm)                 | $\theta(^{\circ})$ |
|-------|--------------|--------------|---------------|-----------------------|--------------------|
| Value | $A \geq 300$ | $B \geq 250$ | $C \leq 8000$ | $600 \leq D \leq 760$ | $\theta \leq 15$   |

Fig. 3.18 Plan 1

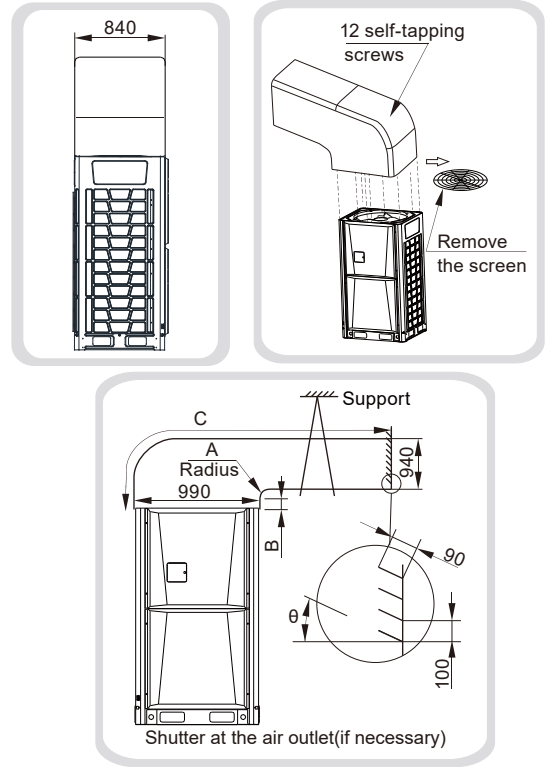

| Size  | A(mm)        | B(mm)        | C(mm)         | $\theta(^{\circ})$ |
|-------|--------------|--------------|---------------|--------------------|
| Value | $A \geq 300$ | $B \geq 250$ | $C \leq 8000$ | $\theta \leq 15$   |

Fig. 3.19 Plan 2

#### 2) 14HP~16HP

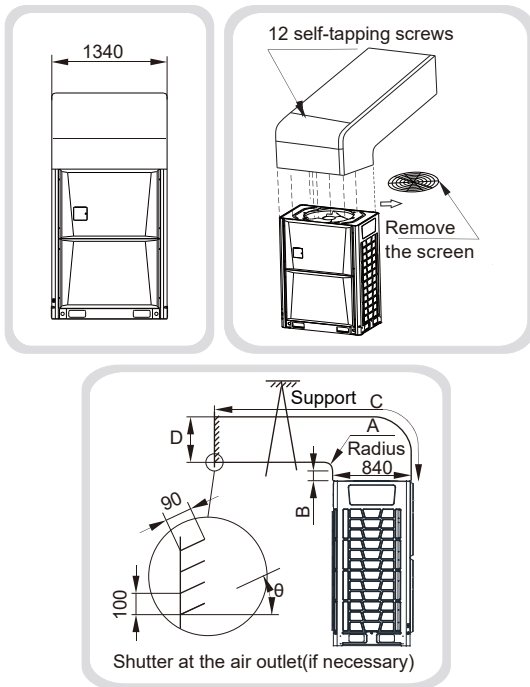

| Size  | A(mm)        | B(mm)        | C(mm)         | D(mm)                 | $\theta(^{\circ})$ |
|-------|--------------|--------------|---------------|-----------------------|--------------------|
| Value | $A \geq 300$ | $B \geq 250$ | $C \leq 8000$ | $600 \leq D \leq 760$ | $\theta \leq 15$   |

Fig. 3.20 Plan 1

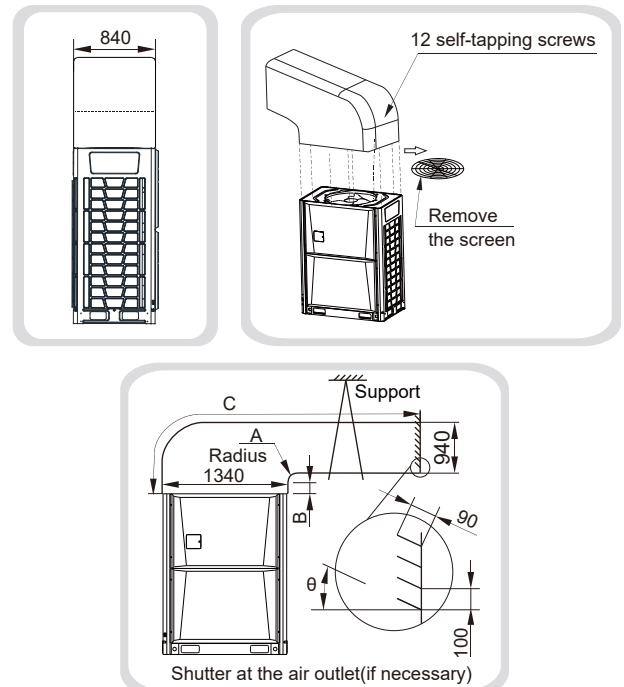

| Size  | A(mm)        | B(mm)        | C(mm)         | $\theta(^{\circ})$ |
|-------|--------------|--------------|---------------|--------------------|
| Value | $A \geq 300$ | $B \geq 250$ | $C \leq 8000$ | $\theta \leq 15$   |

Fig. 3.21 Plan 2

### 3. Installation of outdoor unit

#### 3) 18HP~20HP

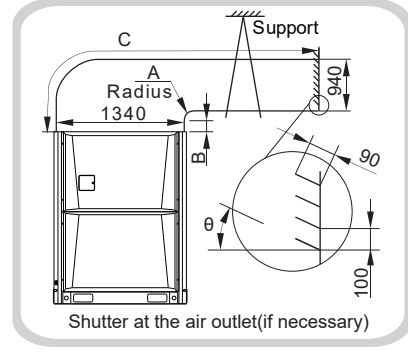
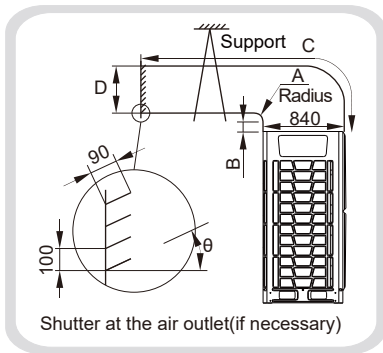
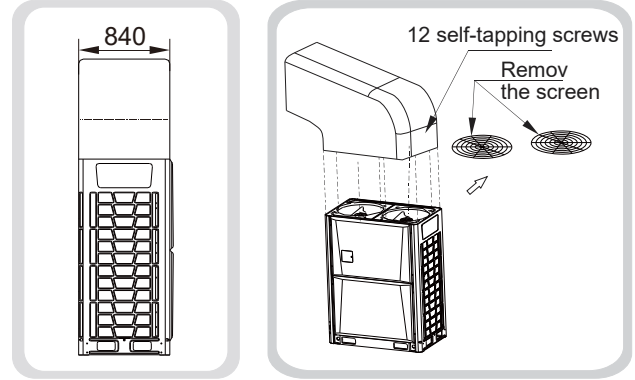
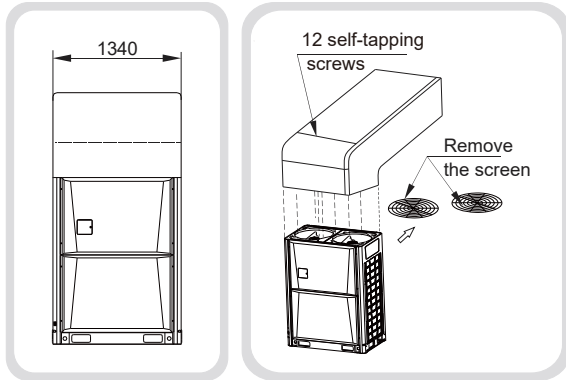

| Size  | A(mm)        | B(mm)        | C(mm)         | D(mm)                 | $\theta(^{\circ})$ |
|-------|--------------|--------------|---------------|-----------------------|--------------------|
| Value | $A \geq 300$ | $B \geq 250$ | $C \leq 8000$ | $600 \leq D \leq 760$ | $\theta \leq 15$   |

Fig. 3.22 Plan 1

| Size  | A(mm)        | B(mm)        | C(mm)         | $\theta(^{\circ})$ |
|-------|--------------|--------------|---------------|--------------------|
| Value | $A \geq 300$ | $B \geq 250$ | $C \leq 8000$ | $\theta \leq 15$   |

Fig. 3.23 Plan 2

#### 4) 22HP

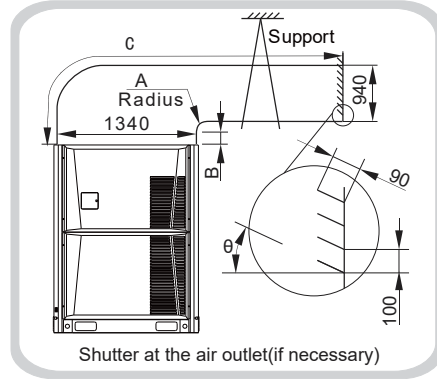
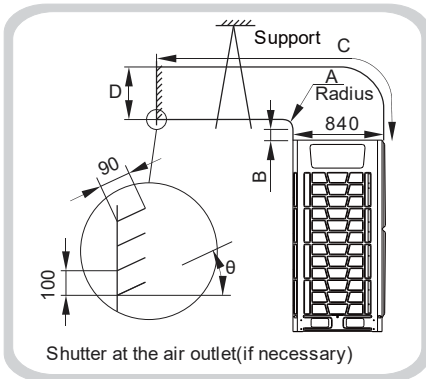
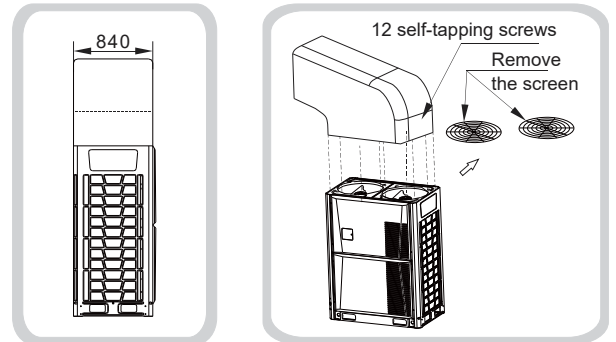
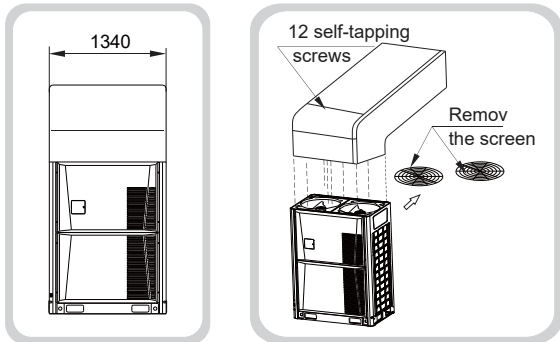

| Size  | A(mm)        | B(mm)       | C(mm)         | D(mm)                 | $\theta(^{\circ})$ |
|-------|--------------|-------------|---------------|-----------------------|--------------------|
| Value | $A \geq 300$ | $B \geq 50$ | $C \leq 8000$ | $600 \leq D \leq 760$ | $\theta \leq 15$   |

Fig. 3.24 Plan 1

| Size  | A(mm)        | B(mm)        | C(mm)         | $\theta(^{\circ})$ |
|-------|--------------|--------------|---------------|--------------------|
| Value | $A \geq 300$ | $B \geq 250$ | $C \leq 8000$ | $\theta \leq 15$   |

Fig. 3.25 Plan 2



### 3. Installation of outdoor unit

#### 5) 24HP

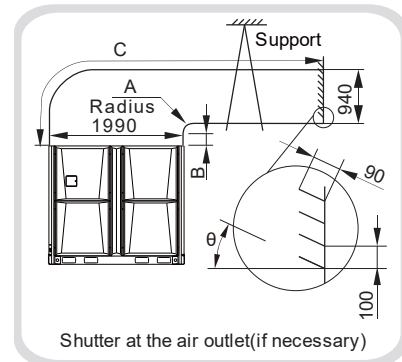
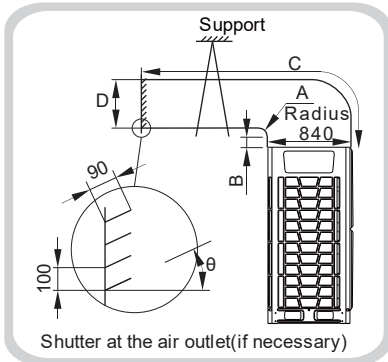
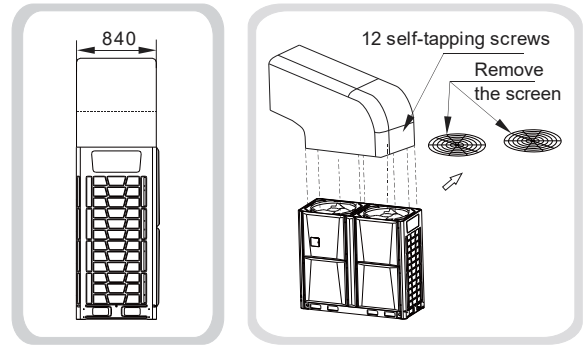
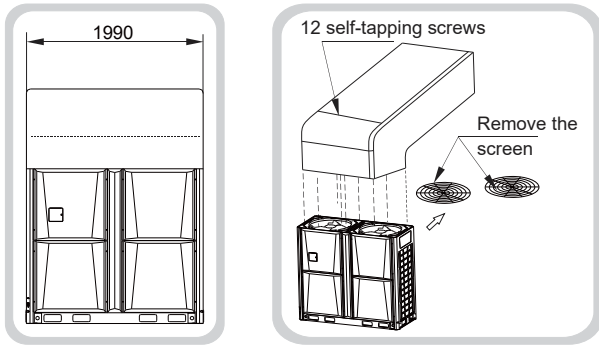

| Size  | A(mm)        | B(mm)        | C(mm)         | D(mm)                 | $\theta(^{\circ})$ |
|-------|--------------|--------------|---------------|-----------------------|--------------------|
| Value | $A \geq 300$ | $B \geq 250$ | $C \leq 8000$ | $600 \leq D \leq 760$ | $\theta \leq 15$   |

| Size  | A(mm)        | B(mm)        | C(mm)         | $\theta(^{\circ})$ |
|-------|--------------|--------------|---------------|--------------------|
| Value | $A \geq 300$ | $B \geq 250$ | $C \leq 8000$ | $\theta \leq 15$   |

Fig. 3.26 Plan 1

Fig. 3.27 Plan 2

#### 6) 26HP~32HP

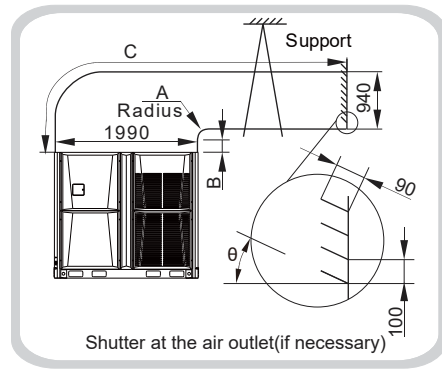
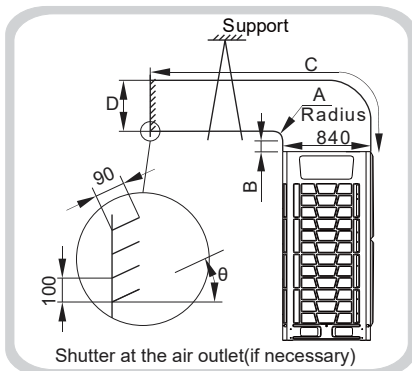
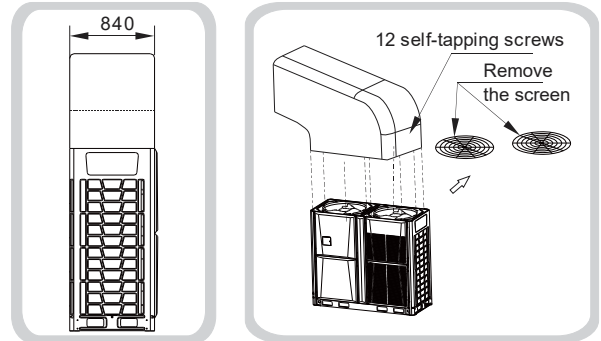
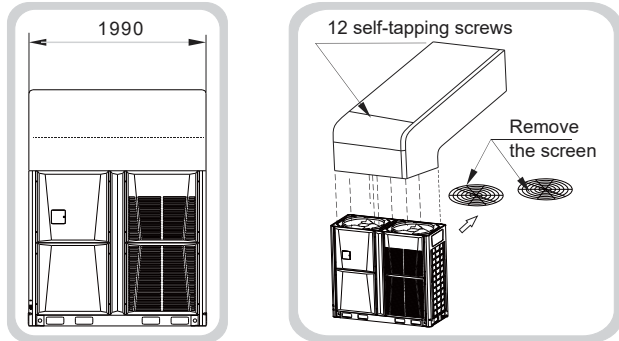

| Size  | A(mm)        | B(mm)        | C(mm)         | D(mm)                 | $\theta(^{\circ})$ |
|-------|--------------|--------------|---------------|-----------------------|--------------------|
| Value | $A \geq 300$ | $B \geq 250$ | $C \leq 8000$ | $600 \leq D \leq 760$ | $\theta \leq 15$   |

| Size  | A(mm)        | B(mm)        | C(mm)         | $\theta(^{\circ})$ |
|-------|--------------|--------------|---------------|--------------------|
| Value | $A \geq 300$ | $B \geq 250$ | $C \leq 8000$ | $\theta \leq 15$   |

Fig. 3.28 Plan 1

Fig. 3.29 Plan 2

## 3. Installation of outdoor unit

### NOTICE

1. The screen shield must be removed before installing the wind scooper, or the air output will be influenced.
2. If the shutter is installed, the air output will be influenced, and the refrigerating or heating capacity and efficiency will be degraded; a larger shutter angle will cause a larger influence, so it is not recommended to use a shutter, and if must, the shutter angle must be controlled within 15°.
3. The air duct can only have one bend (shown as the figure above), or the machine operation will be degraded.

### 3-13 Valves

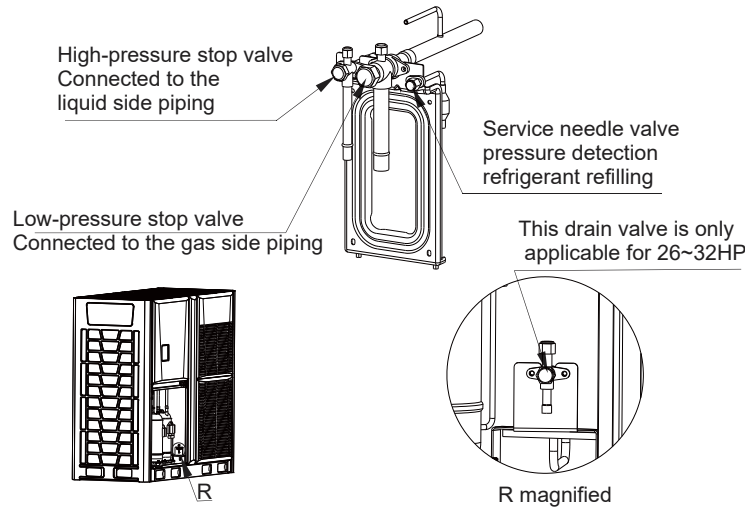

Fig. 3.30 Valves

## 4. Design of refrigerant tube

### 4-1 Refrigerant tube length and height difference

### NOTICE

1. All manifolds must be the special manifolds provided by the manufacturer, or some serious failure may occur to the system!
2. Indoor units shall be uniformly installed at both sides of the “U” shape manifold.

Tab.4.1 Refrigerant tube length and height difference

|                   |  | Allowance  | Tube part (Fig. 4.1)  |
|-------------------|--|--|---|
| Tube length       | Total tube length (Total extension)                    | 1000m(Please refer to following condition 2 of notice 4) | $L1+(L2+L3+L4+L5+L6+L7+L8+L9+L10+L11+L12) \times 2+a+b+c+d+e+f+g+h+i+j+k+l+m$ |
|                   | Longest tube length (L)                                | Actual   | 200m  |
|                   |  | Equivalent   | 240m (Please refer to following notice 1)                                     |
|                   | Furthest length of tube from 1st manifold              | 90m (Please refer to following notice 4)                 | $L7+L8+L9+L10+i$  |
| Height difference | Height difference between indoor and outdoor units (H) | Outdoor top  | 100m  |
|                   |  | Outdoor bottom   | 110m  |
|                   | Height difference between indoor and indoor units (H)  | 40m  | Please refer to following notice 3  |

Remark: the equivalent tube length of the manifold is 0.5m.

## 4. Design of refrigerant tube

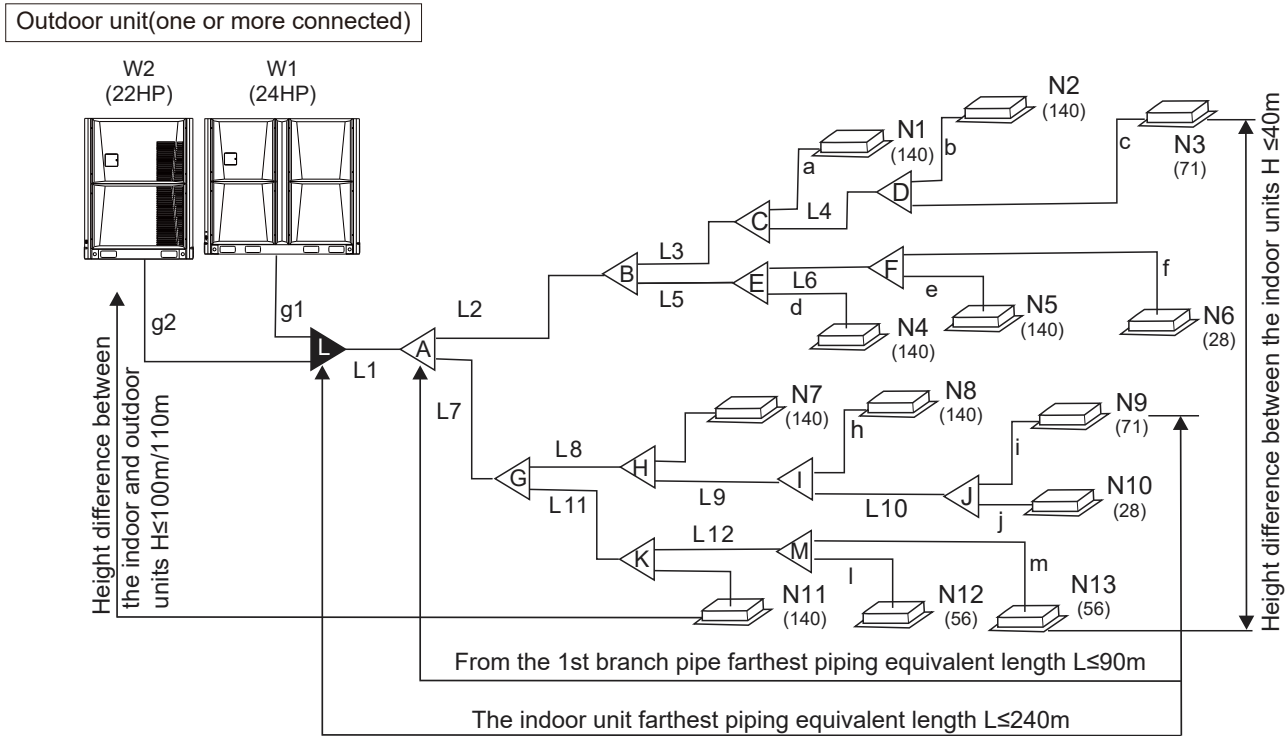

Fig. 4.1 Refrigerant tube length and height difference

### NOTICE

1. The converted length of the manifold is equivalent to 0.5m.
2. The indoor units should be installed equally on both sides of the U-shaped manifold.
3. When the outdoor unit is below and H is higher than 40m, the liquid pipe of the main pipeline needs to be increased by one size.
4. The allowable length of the first manifold assembly connected to the indoor unit should be equal to or less than 40m. But when all the following conditions are met, the allowable length can be extended to 90m.

| Conditions  | Legend  |   |
|---|---|---|
| 1. The diameter of all the main branch tube between the first manifold assembly and the last manifold assembly needs to be increased. (Please make the tube on site)<br>If the diameter of main branch is same as the main tube, then no need to increase it. | N9<br>$L7+L8+L9+L10+i \leq 90m$<br>L2,L3,L4,L5,L6,L7,L8,L9,L10,L11,L12<br>The diameter of above main branch tube need to be increased | Increase tube size as shown below<br>$\phi 9.5 \rightarrow \phi 12.7$ $\phi 12.7 \rightarrow \phi 15.9$ $\phi 15.9 \rightarrow \phi 19.1$ $\phi 19.1 \rightarrow \phi 22.2$ $\phi 22.2 \rightarrow \phi 25.4$ $\phi 25.4 \rightarrow \phi 28.6$ $\phi 31.8 \rightarrow \phi 38.1$ $\phi 38.1 \rightarrow \phi 41.2$ $\phi 41.2 \rightarrow \phi 44.5$ $\phi 44.5 \rightarrow \phi 54.0$ |
| 2. When calculating the total extension length, the actual length of the above main branch tube must be doubled. (Except for main tube and branch tube without increasing the pipe diameter.)   | $L1+(L2+L3+L4+L5+L6+L7+L8+L9+L10+L11+L12) \times 2 + a+b+c+d+e+f+g+h+i+j+k+l+m \leq 1000m$  | Figure. 4.1   |
| 3. The length between indoor unit and nearest manifold assembly is less than or equal to 20m.   | a,b,c...m $\leq 20m$<br>(For tube size, please refer to Table 4.4)  |   |
| 4. The difference between [the length between outdoor and furthest indoor] and [the length between outdoor and nearest indoor] is less than or equal to 40m.  | The furthest indoor N9<br>The nearest indoor N1<br>$(L1+L7+L8+L9+L10+i)-(L1+L2+L3+a) \leq 40m$  |   |

5. All manifolds must use our special tube. Failure to operate in accordance with this requirement may lead to serious system failure!

# 4. Design of refrigerant tube

## 4-2 Tube classification

Tab.4.2 Tube classification

| Tube name                          | Connecting position  | Code (Fig. 4.2)                 |
|------------------------------------|--|---------------------------------|
| Main tube                          | Tube from the outdoor unit to the first indoor branch                            | L <sub>1</sub>                  |
| Main tube for indoor unit          | Tube after the first indoor manifold and indirectly connected to the indoor unit | L <sub>2</sub> ~L <sub>12</sub> |
| Branch tube for indoor unit        | Tube after the manifold and directly connected to the indoor unit                | a,b,c,d,e,f,g,h,i,j,k,l,m       |
| Manifold assembly for indoor unit  | Tube assembly for connecting the maintube, main branch tube and branch tube      | A,B,C,D,E,F,G,H,I,J,K,M         |
| Manifold assembly for outdoor unit | Tube assembly for connecting the outdoor tube and main tube                      | L                               |
| Connecting tube for outdoor unit   | Tube connecting the outdoor unit to the outdoor manifold                         | g <sub>1</sub> , g <sub>2</sub> |

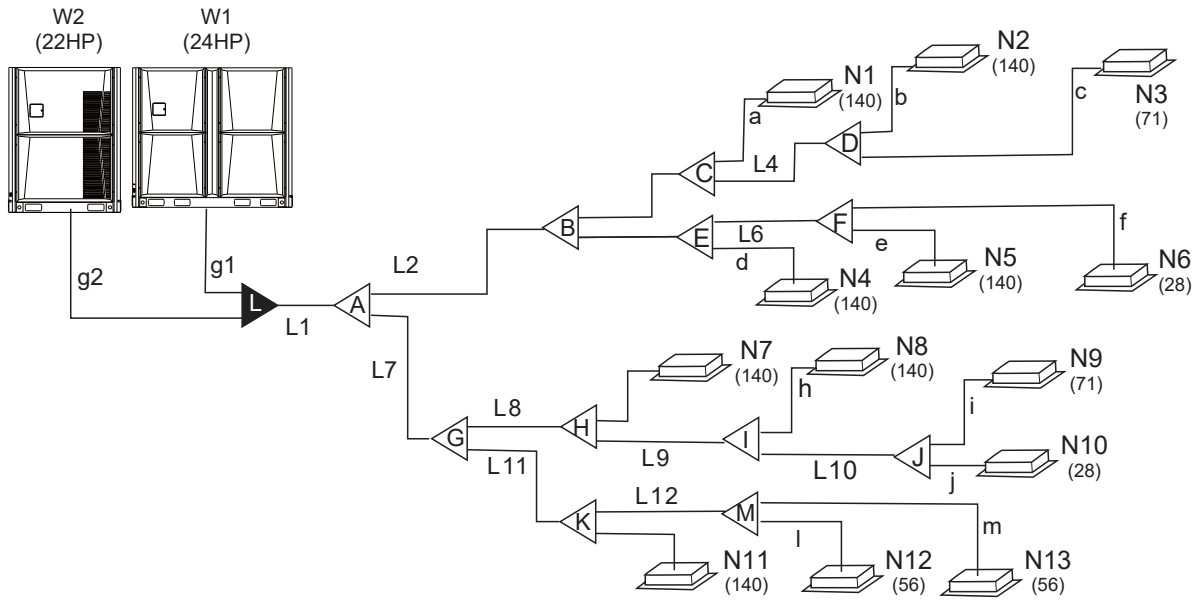

Fig. 4.2 Tube classification

## 4-3 Diameters of main tubes for indoor unit

- See Tab. 4.3 for the diameters of main tubes (L<sub>2</sub>~L<sub>9</sub>) for R410A indoor unit.
- E.g.: The capacity of downstream indoor units after L<sub>2</sub> in Fig. 4.2 is 140×4+28+71=659, so the gas tube and liquid tube of L<sub>2</sub> are respectively: Φ28.6 and Φ15.9.

Tab.4.3 Diameters of main tubes for R410A indoor unit

| Capacity of downstream units(×100W) | Tube diameter of indoor unit(mm) |             | Applicable manifold |
|-------------------------------------|----------------------------------|-------------|---------------------|
|                                     | Gas tube                         | Liquid tube |                     |
| A<168                               | Φ15.9                            | Φ9.5        | SP-FQG-N01D         |
| 168≤A<224                           | Φ19.1                            | Φ9.5        |                     |
| 224≤A<330                           | Φ22.2                            | Φ9.5        | SP-FQG-N02D         |
| 330≤A<470                           | Φ28.6                            | Φ12.7       | SP-FQG-N03D         |
| 470≤A<710                           | Φ28.6                            | Φ15.9       |                     |
| 710≤A<1040                          | Φ31.8                            | Φ19.1       |                     |
| 1040≤A<1540                         | Φ38.1                            | Φ19.1       | SP-FQG-N04D         |
| 1540≤A<1800                         | Φ41.2                            | Φ19.1       | SP-FQG-N05D         |
| 1800≤A<2450                         | Φ44.5                            | Φ22.2       |                     |
| 2450≤A<2690                         | Φ54.0                            | Φ25.4       | SP-FQG-N06D         |
| 2690≤A                              | Φ54.0                            | Φ28.6       | SP-FQG-N07D         |

## 4. Design of refrigerant tube

### 4-4 Diameters of branch tubes for indoor unit

Tab.4.4 Length of branch tubes

| Capacity of indoor units A(×100W) | If the branch tube length≤10m |                 | If the branch tube length>10m |                 |
|-----------------------------------|-------------------------------|-----------------|-------------------------------|-----------------|
|                                   | Gas side(mm)                  | Liquid side(mm) | Gas side(mm)                  | Liquid side(mm) |
| A≤28                              | Φ9.5                          | Φ6.35           | Φ12.7                         | Φ9.5            |
| 28<A≤56                           | Φ12.7                         | Φ6.35           | Φ15.9                         | Φ9.5            |
| 56<A≤160                          | Φ15.9                         | Φ9.5            | Φ19.1                         | Φ12.7           |

### 4-5 Diameters of main tubes for outdoor unit

Tab.4.5 Diameters of main tubes for R410A outdoor unit(1)

| Capacity of outdoor units(HP) | When the equivalent length of all tubes < 90m |                 |                     |
|-------------------------------|---|-----------------|---------------------|
|                               | Gas side(mm)                                  | Liquid side(mm) | Indoor 1st manifold |
| 8                             | Φ19.1   | Φ9.5            | SP-FQG-N02D         |
| 10                            | Φ22.2   | Φ9.5            |                     |
| 12~14                         | Φ25.4   | Φ12.7           |                     |
| 16                            | Φ28.6   | Φ12.7           | SP-FQG-N03D         |
| 18~24                         | Φ28.6   | Φ15.9           |                     |
| 26~34                         | Φ31.8   | Φ19.1           | SP-FQG-N04D         |
| 36~54                         | Φ31.8   | Φ19.1           | SP-FQG-N03D         |
| 56~66                         | Φ41.2   | Φ19.1           | SP-FQG-N05D         |
| 68~82                         | Φ44.5   | Φ22.2           |                     |
| 84~96                         | Φ50.8   | Φ25.4           |                     |

Tab.4.6 Diameters of main tubes for R410A outdoor unit(2)

| Capacity of outdoor units(HP) | The equivalent length of all tubes ≥ 90m |                 |                     |
|-------------------------------|--|-----------------|---------------------|
|                               | Gas side(mm)                             | Liquid side(mm) | Indoor 1st manifold |
| 8                             | Φ22.2                                    | Φ12.7           | SP-FQG-N02D         |
| 10                            | Φ25.4                                    | Φ12.7           |                     |
| 12~14                         | Φ28.6                                    | Φ15.9           | SP-FQG-N03D         |
| 16                            | Φ31.8                                    | Φ15.9           |                     |
| 18~24                         | Φ31.8                                    | Φ19.1           |                     |
| 26~34                         | Φ38.1                                    | Φ22.2           | SP-FQG-N04D         |
| 36~54                         | Φ41.2                                    | Φ22.2           |                     |
| 56~66                         | Φ44.5                                    | Φ22.2           | SP-FQG-N05D         |
| 68~82                         | Φ54.0                                    | Φ25.4           | SP-FQG-N06D         |
| 84~96                         | Φ54.0                                    | Φ28.6           | SP-FQG-N07D         |

Please select the main tube as per the table above. If indoor units are excessively equipped and the main manifold for indoor units is larger than the main tube, the main tube shall be selected as per the diameter of the main manifold, i.e. select the larger one.

E.g.: When three outdoor units (24+22) are parallel connected (total capacity 46HP), and the capacity of all indoor units connected is 1290, if the equivalent length of all tubes is less than 90m, refer to Tab.4.5: the main tube for a total outdoor capacity 46HP is Φ41.2/Φ22.2; but refer to Tab.4.3, the main manifold for a total indoor capacity 1290 is Φ38.1/Φ19.1, so according to the principle for selecting the larger one, the main tube is finally fixed in Φ41.2/Φ22.2.

# 4. Design of refrigerant tube

## 4-6 Diameters of own interface on the outdoor unit

Tab.4.7 Diameter of interface on outdoor unit

| Type                          | Tube side | Gas side(mm) | Liquid side(mm) |
|-------------------------------|-----------|--------------|-----------------|
| 8HP/10HP/12HP                 |           | Φ22.2        | Φ12.7           |
| 14HP/16HP/18HP/20HP/22HP/24HP |           | Φ28.6        | Φ15.9           |
| 26HP/28HP/30HP/32HP           |           | Φ35          | Φ22.2           |

## 4-7 Selection of parallel tube assembly and parallel tube diameter for outdoor units

Please select the tube as per the Tab.4.8.

Tab.4.8 Tube assemblies for multi-connected outdoor units

| No. of outdoor units | Legend | Outdoor tube diameter (mm)  | Parallel manifold assembly          | Main tube            |
|----------------------|--------|---|-------------------------------------|----------------------|
| 2 sets               |        | g1, g2:<br>8-12HP: Φ25.4/Φ12.7;<br>14-24HP: Φ31.8/Φ15.9;<br>26-32HP: Φ38.1/Φ19.1;                         | L:<br>SP-FQG-W2F or<br>SP-FQG-W2D   | Refer to Tab.4.5/4.6 |
| 3 sets               |        | g1, g2, g3:<br>8-12HP: Φ25.4/Φ12.7;<br>14-24HP: Φ31.8/Φ15.9;<br>26-32HP: Φ38.1/Φ19.1;<br>G1: Φ41.2/Φ22.2; | L+M:<br>SP-FQG-W3F or<br>SP-FQG-W3D |                      |
| 4 sets               |        | g1, g2, g3:<br>8-12HP: Φ25.4/Φ12.7;<br>14-24HP: Φ31.8/Φ15.9;<br>G1: Φ38.1/Φ19.1;<br>G2: Φ41.2/Φ22.2       | L+M+N:<br>SP-FQG-W4D                |                      |

Remark: Tube assemblies in the table above are the manufacturer special parts which must be separately ordered.

## 4-8 Example of a whole pipeline

E.g.: A combination of two modules (24HP+22HP) is herein used for explaining the selection of tubes.

Imagine the equivalent length of all tubes in the schematic system is larger than 90m.

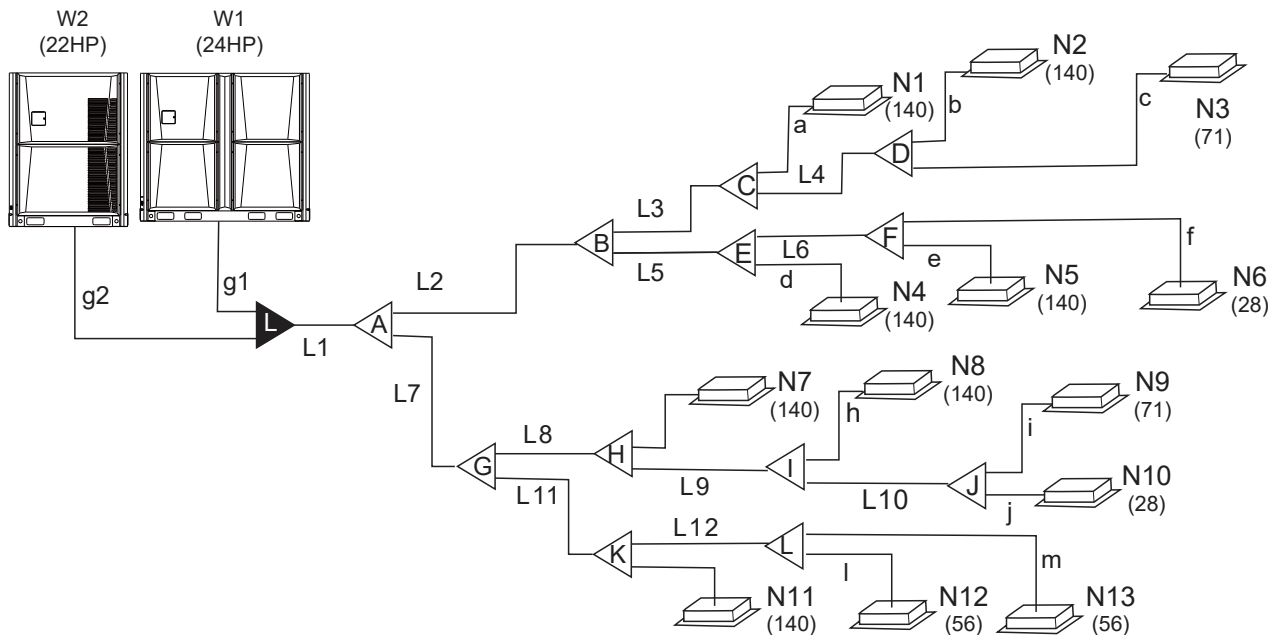

Fig. 4.3

## 4. Design of refrigerant tube

### 1) Main branch tube for indoor units

1. The total capacity of downstream units N2 and N3 after the main tube L4 is  $140+71=211$ , tube L4 is  $\Phi 19.1/\Phi 9.5$ , and manifold D is SP-FQG-N01D.

2. The total capacity of downstream units N1~N3 after the main tube L3 is  $140\times 2+71=351$ , tube L3 is  $\Phi 28.6/\Phi 12.7$ , and manifold C is SP-FQG-N03D.

3. The total capacity of downstream units N5~N6 after the main tube L3 is  $140+28=168$ , tube L6 is  $\Phi 19.1/\Phi 9.5$ , and manifold F is SP-FQG-N01D.

4. The total capacity of downstream units N4~N6 after the main tube L5 is  $140\times 2+28=308$ , tube L5 is  $\Phi 22.2/\Phi 9.5$ , and manifold E is SP-FQG-N02D.

5. The total capacity of downstream units N1~N6 after the main tube L2 is  $140\times 4+71+28=659$ , tube L2 is  $\Phi 28.6/\Phi 15.9$ , and manifold B is SP-FQG-N03D.

6. The total capacity of downstream units N9 and N10 after the main tube L10 is  $71+28=99$ , tube L10 is  $\Phi 15.9/\Phi 9.5$ , and manifold J is SP-FQG-N01D.

7. The total capacity of downstream units N8~N10 after the main tube L9 is  $140+71+28=239$ , tube L9 is  $\Phi 22.2/\Phi 9.5$ , and manifold I is SP-FQG-N02D.

8. The total capacity of downstream units N7~N10 after the main tube L8 is  $140\times 2+71+28=379$ , tube L8 is  $\Phi 28.6/\Phi 12.7$ , and manifold H is SP-FQG-N03D.

9. The total capacity of downstream units N12 and N13 after the main tube L12 is  $56\times 2=112$ , tube L12 is  $\Phi 15.9/\Phi 9.5$ , and manifold L is SP-FQG-N01D.

10. The total capacity of downstream units N11~N13 after the main tube L11 is  $140+56\times 2=252$ , tube L11 is  $\Phi 22.2/\Phi 9.5$ , and manifold K is SP-FQG-N02D.

11. The total capacity of downstream units N7~N13 after the main tube L7 is  $140\times 3+71+56\times 2+28=631$ , tube L7 is  $\Phi 28.6/\Phi 15.9$ , and manifold G is SP-FQG-N03D.

12. The total capacity of downstream units N1~N13 after manifold A is  $140\times 7+71\times 2+56\times 2+28\times 2=1290$ , and manifold A is SP-FQG-N04D.

### 2) Main tube (refer to Tab.4.3/4.5/4.6)

The total capacity of upstream outdoor units before the main tube L1 in Fig. 4.3 is  $24+22=46\text{HP}$ , referring to Tab.4.5/4.6 it is known the gas tube/ liquid tube= $\Phi 38.1/\Phi 22.2$  while the total capacity of downstream units is  $140\times 7+71\times 2+56\times 28\times 2=1290$ , referring to Tab.4.3 it is known the gas tube/ liquid tube= $\Phi 38.1/\Phi 19.1$ , so according to the principle for selecting the larger one, the main tube specification is finally fixed in  $\Phi 38.1/\Phi 22.2$ .

### 3) Main tube for outdoor units

Referring to <Installation Instruction of Outdoor Manifold>, it is known that g1: $\Phi 38.1/\Phi 19.1$ , g2: $\Phi 31.8/\Phi 15.9$ , L:SP-FQG-W2F.

## 4-9 Removal of impurities and water in the tube

1) Impurities may enter when the refrigerant tubes are being installed, so they must be cleaned before tubes are connected to each outdoor unit.

2) The pipeline can be cleaned by high pressure nitrogen gas other than the refrigerant of any outdoor unit.

## 4-10 Gas tightness test

1) When the indoor tube is connected, the high pressure tube can be welded to the surface joint, as shown in the figure below.

2) Weld the low pressure tube to the surface joint, as shown is the figure below.

3) Firstly, exhaust the system air from the valve core of the liquid-side shut-off valve and the gas-side shut-off valve by a vacuum pump until the gauge pressure showing  $-1\text{kg}/\text{cm}^2$ .

4) Then shut down the vacuum pump, and charge  $40\text{kgf}/\text{cm}^2$  nitrogen from the valve core of the shut-off valve on both the gas and liquid sides, and maintain the pressure for 24 hours.

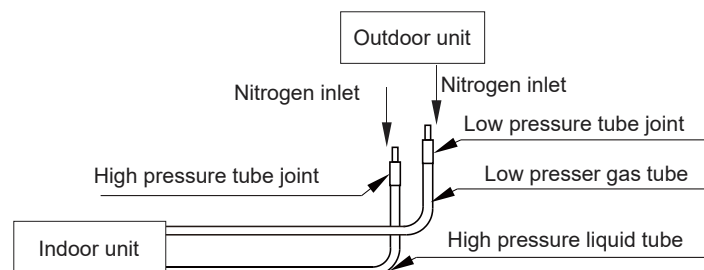

Fig. 4.4 Gas tightness test

## 4. Design of refrigerant tube



### NOTICE

1. Gas tightness test is performed by pressurized nitrogen gas (4.0MPa, i.e. 40kgf/cm<sup>2</sup>).
2. Gas tightness test cannot be performed by oxygen gas, inflammable gas or toxic gas.
3. Gas tightness test must be performed by injecting the high pressure nitrogen gas from the high pressure side and low pressure side at the same time, or the indoor electronic expansion valve core may be damaged by the excessively high pressure at one side.
4. The low pressure valve must be protected by piece of wet cloth during welding.

### 4-11 Vacuumizing by a vacuum pump

- 1) The vacuum degree of the vacuum pump is -0.1MPa below and the air flow rate is 40L/min above.
- 2) Vacuumization for the outdoor unit is unnecessary, and it is forbidden to open the check valves at the gas side and liquid side of the outdoor unit.
- 3) Make sure the vacuum pump can reach -0.1MPa below within 2 hours, and if it fails to reach -0.1MPa below after 3 hours, it means some water or air has mixed inside, and the pump and pipeline system must be inspected.

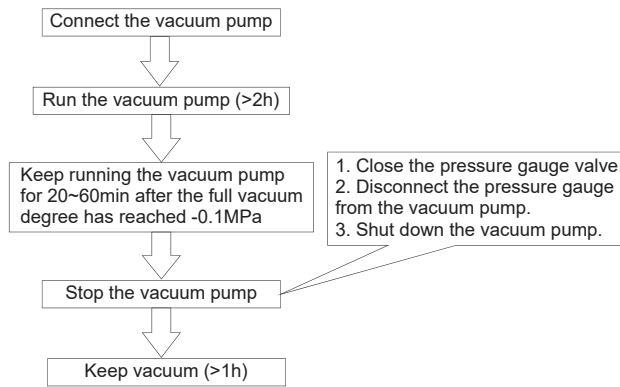

Fig. 4.5 Vacuumizing



### NOTICE

1. Tools and measuring apparatus for different refrigerants or directly contacting the refrigerant cannot be mixed for using.
2. Refrigerant gas cannot be used for air impelling.
3. If the vacuum degree cannot reach -0.1MPa, please check if there is some leakage, and if not, please make the vacuum further run for 1~2h.

### 4-12 Refrigerant refilling volume

The volume of refrigerant to be refilled (R410A) is calculated as per the diameter and length of tube at the liquid side of the outdoor and indoor units.

Tab.4.9 Refrigerant refilling volume

| Diameter of tube at the liquid side(mm) | Refrigerant to be refilled for every 1m of tube length(kg) |
|---|--|
| Φ6.35                                   | 0.022  |
| Φ9.5                                    | 0.057  |
| Φ12.7                                   | 0.110  |
| Φ15.9                                   | 0.160  |
| Φ19.1                                   | 0.210  |
| Φ22.2                                   | 0.360  |
| Φ25.4                                   | 0.520  |
| Φ28.6                                   | 0.680  |



### NOTICE

- 1.Refrigerant R410A must be weighed for refilling by an electronic weigher in the liquid mode.



# 4. Design of refrigerant tube

## 4-13 Key points for the installation of outdoor tubes

- 1) Tubes for outdoor units must be horizontally arranged (Fig. 4.6 and Fig. 4.7), and no sagging is permitted in the middle section, as shown in Fig. 4.8.
- 2) Tubes for outdoor units cannot be higher than the tube interface of each unit, as shown in Fig. 4.9.
- 3) The manifold shall be installed as horizontally as possible, and the angle error shall be controlled within  $10^\circ$ , as any fault may happen if it is not correctly installed, as shown in Fig. 4.10.

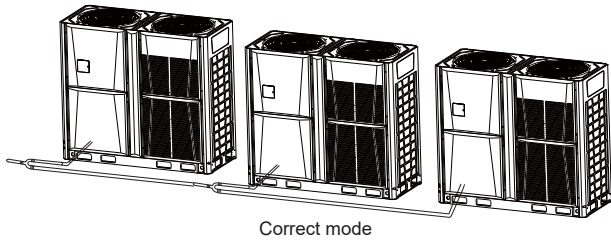

Correct mode  
Fig. 4.6 Mode 1

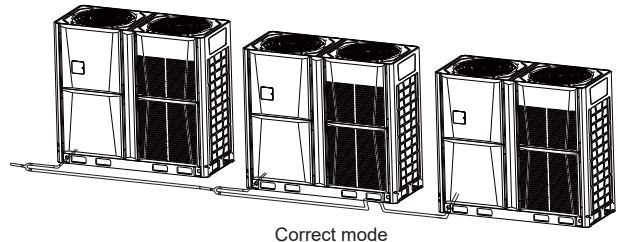

Correct mode  
Fig. 4.7 Mode 2

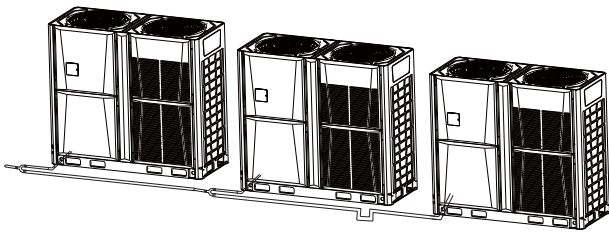

Incorrect mode  
Fig. 4.8 Mode 3

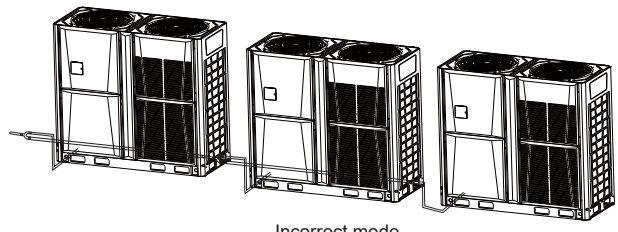

Incorrect mode  
Fig. 4.9 Mode 4

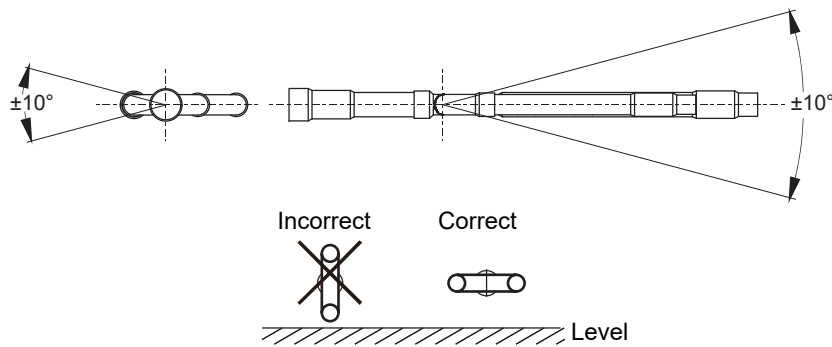

Fig. 4.10 Manifold assemblies installation

- 4) Manifold assemblies must be correctly installed to prevent oil accumulation in the outdoor unit.

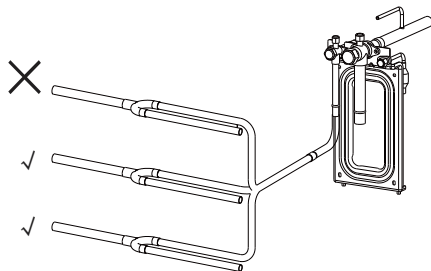

Fig. 4.11 Installation 1

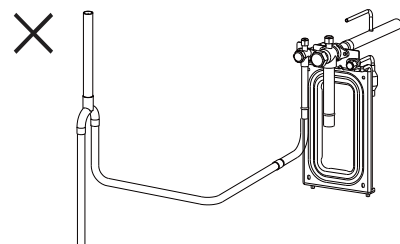

Fig. 4.12 Installation 2

## 5. Electrical wiring

### 5-1 Spot inspection for outdoor unit(Tab.5.1)

Tab.5.1 Descriptions for spot inspection

| No. | Display   | Reference values  |
|-----|---|---|
|     | Current frequency(indoor unit quantity when unit in standby mode) |   |
| 1   | This outdoor unit address   | 0, 1, 2, 3  |
| 2   | This outdoor unit capacity address                                | 0-F, The corresponding number of outdoor units is shown in the table on the nameplate of the outdoor unit |
| 3   | Number of online outdoor units                                    | Available for master unit only  |
| 4   | Total capacity of outdoor units                                   | When paralleling, available for master unit only  |
| 5   | Number of outdoor units in operation                              | Master display only   |
| 6   | Total HP of outdoor units in operation                            | Master-slave display  |
| 7   | Maximum online indoor units quantities                            | The maximum total number of indoor units used to communicate with outdoor units                           |
| 8   | Current online indoor units quantities                            | Current total number of indoor units communicating with outdoor units                                     |
| 9   | Quantities of indoor units in operation                           | Current total number of indoor units with cooling or heating mode   |
| 10  | Running mode  | 0: Off or fan only 2: Cooling only 3: Heating only 4: Forced cooling 5: Forced heating                    |
| 11  | Total capacity demand of indoor units                             | Available for master unit only  |
| 12  | Amended capacity demand for the master unit                       | Available for master unit only  |
| 13  | Output capacity of outdoor unit                                   | Actual output HP  |
| 14  | Low pressure value  | Actual value= Display value * 0.01 (Mpa)  |
| 15  | High pressure value   | Actual value= Display value * 0.1 (Mpa)   |
| 16  | Fan speed range   | 0~36  |
| 17  | Average temperature of evaporators T2/T2B                         | Actual value (°C)   |
| 18  | Temperature of condenser outlet T3                                | Actual value (°C)   |
| 19  | Ambient temperature T4  | Actual value (°C)   |
| 20  | Temperature of T5 sensor  | (Reserved)actual value(°C)  |
| 21  | Inlet temperature(T6A) of plate heat exchanger                    | Actual value (°C)   |
| 22  | Outlet temperature(T6B) of plate heat exchanger                   | Actual value (°C)   |
| 23  | Discharge temperature of inverter compressor A                    | Actual value (°C)   |
| 24  | Discharge temperature of inverter compressor B                    | Actual value (°C)   |
| 25  | T8  | Refrigerant cooling copper tube temperature   |
| 26  | Temperature of IPM A  | Actual value (°C) , Internal temperature of IPM   |
| 27  | Temperature of IPM B  | Actual value (°C) , Internal temperature of IPM   |
| 28  | Superheat degree of compressor                                    | Actual value (°C)   |
| 29  | Opening degree of EXV A   | 8-24HP: Actual value = Display value * 8; 26-32HP: Actual value = Display value * 8*6                     |
| 30  | Opening degree of EXV C   | Actual value = Display value * 8  |
| 31  | Auxiliary valve adjustment interval                               | 0-OFF; 1-Minimum opening; 2-Automatic adjustment  |
| 32  | Current of inverter compressor A                                  | Actual value (A)  |
| 33  | Current of inverter compressor B                                  | Actual value (A)  |
| 34  | Secondary side current of inverter compressor A                   | Actual value (A)  |
| 35  | Secondary side current of inverter compressor B                   | Actual value (A)  |
| 36  | AC voltage  | Actual value (V)  |
| 37  | DC bus line voltage of compressor A                               | Actual value = Display value * 4(V)   |
| 38  | DC bus line voltage of compressor B                               | Actual value = Display value * 4(V)   |

## 5. Electrical wiring

|    |   |  |
|----|---|--|
| 39 | Priority mode                                   | 0: Auto priority 1: Heating priority 2: Cooling priority 3: Heating only<br>4: Cooling only 5: VIP priority and auto priority  |
| 40 | Silence mode                                    | 0: Standard mode 1: Silence mode1 2: Silence mode2 3: Silence mode3<br>4: Night silence mode   |
| 41 | Static pressure mode                            | 0: Standard mode 1: Low pressure 2: Medium pressure 3: High pressure<br>4: Super high pressure   |
| 42 | VIP indoor unit address                         |  |
| 43 | Refrigerant status                              | 0: Normal 1: Excessive refrigerant 2: Serious excessive refrigerant<br>11: Lack of refrigerant 12: Lack of much refrigerant 13: Lack of too much refrigerant   |
| 44 | T2B condition A                                 | Factory default 8, setting range: 5-15   |
| 45 | T2 condition B                                  | Factory default 44, setting range: 40-50   |
| 46 | Energy saving value                             | Factory default 100%, setting range: 100%-40%  |
| 47 | Maximum defrost time                            | Factory default 10 minutes, setting range: 5-20 minutes  |
| 48 | Defrosting T3 temperature exit condition        | Factory default 15°C, setting range: 10-18°C   |
| 49 | Allowed offline time of indoor unit             | Factory default 60 minutes, can be set as 60,120,180,240,480   |
| 50 | Number of allowed offline indoor units          | Factory default 2, setting range: 0-6  |
| 51 | Reserved  | Reserved   |
| 52 | T2B correction plus or minus                    | 0-No correction 4-Unit number correction(No T2B average correction)<br>5-Number of units+T2B average correction+3 6-Number of units+T2B  |
| 53 | Reserved  | Reserved   |
| 54 |   |  |
| 55 | Compressor A & B drive code                     | 1: AA55 4:VC060 6: DC80 7: DD98 8:VC070  |
| 56 |   |  |
| 57 | Frequency limitation of inverter compressor A&B | 0: Unlimited frequency 1: T4 frequency limiting 2: Pressure frequency limiting<br>3: Voltage frequency limiting 4: Exhaust frequency limiting<br>5: Current frequency limiting 6: P6 frequency limiting 7: Module temperature limiting |
| 58 |   |  |
| 59 | Reserved  | Reserved   |
| 60 | Last time error fault or protection code        | No protection or fault display 00  |



### NOTICE

1. At standby, it displays the number of indoor units, and when there is a demand for capacity, it displays the running frequency of the compressor (number of indoor units means the number of units communicating with the outdoor unit).
2. Outdoor unit running mode: 0-Off/Fan mode; 2-Cooling; 3-Heating; 4-Forced cooling.
3. Indoor unit running mode limit: 0-auto priority; 1-heating priority; 2-cooling priority; 3-heating only; 4-cooling only; 5-VIP priority and auto priority.

# 5. Electrical wiring

## 5-2 Dialing code indication mark

See Tab.5.2 and Tab.5.3.

Tab.5.2 Dialing code 1

| SN  | Definition                            | Legend | Function  | SN   | Definition                                | Legend              | Function   |
|-----|---------------------------------------|--------|---|------|---|---------------------|--|
| SW4 | The night time silent mode selection  |        | The night time is selected as 6h/10h (factory default)                            | SW8  | Night silent and address setting function |                     | Night silent mode and automatic addressing (factory default) |
|     |                                       |        | The night time is selected as 8h/10h  |      |   |                     | Night silent mode and non automatic addressing               |
|     |                                       |        | The night time is selected as 6h/12h  |      |   |                     | Reserved   |
|     |                                       |        | The night time is selected as 8h/8h   |      |   |                     | Non night silent mode and automatic addressing               |
| SW5 | Static Pressure set selection         |        | Standard static pressure (factory default)  | SW9  | Mode selection                            |                     | Non night silent mode and non automatic addressing           |
|     |                                       |        | Low static pressure   |      |   |                     | Auto priority (factory default)                              |
|     |                                       |        | Middle static pressure  |      |   |                     | Heating priority   |
|     |                                       |        | High static pressure  |      |   |                     | Cooling priority   |
|     |                                       |        | Super static pressure   |      |   |                     | Heating only   |
|     |                                       |        | Silence   |      |   |                     | Cooling only   |
|     |                                       |        | High silence  |      |   |                     | VIP No.63 address &Automatic priority                        |
|     |                                       |        | Super-silence   |      |   |                     | Reserved   |
| SW7 | Start time set and anti-snow function |        | The start time is set as 12 minutes, without anti-snow function (factory default) | SW12 | Power check function                      |                     | Reserved   |
|     |                                       |        | The start time is set as 7 minutes, without anti-snow function                    | SW13 |   | Fan motor selection |  |
|     |                                       |        | The start time is set as 12 minutes, with anti-snow function                      |      |   |                     | Reserved   |
|     |                                       |        | The start time is set as 7minutes, with anti-snow function                        |      |   |                     |  |

## 5. Electrical wiring

Tab.5.3 Dialing code 2

### SW6 Outdoor address setting

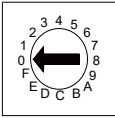
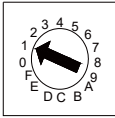
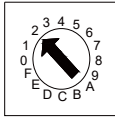
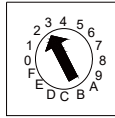
|   |   |   |   |
|---|---|---|---|
|  |  |  |  |
| 0   | 1   | 2   | 3   |
| Master  | Slave 1   | Slave 2   | Slave 3   |

### SW11 Outdoor capacity setting

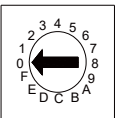
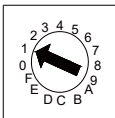
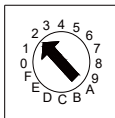
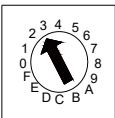
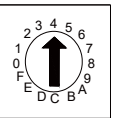
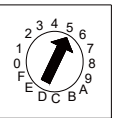
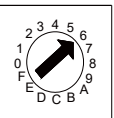
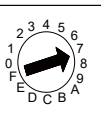
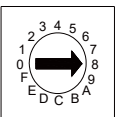
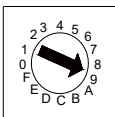
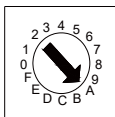
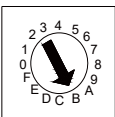
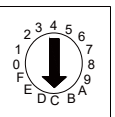
|   |   |   |   |   |   |   |   |
|---|---|---|---|---|---|---|---|
|  |  |  |  |  |  |  |  |
| 0   | 1   | 2   | 3   | 4   | 5   | 6   | 7   |
| 8HP   | 10HP  | 12HP  | 14HP  | 16HP  | 18HP  | 20HP  | 22HP  |
|  |  |  |  |  |   |   |   |
| 8   | 9   | A   | B   | C   | D   | E   | F   |
| 24HP  | 26HP  | 28HP  | 30HP  | 32HP  | Reserved  | Reserved  | Reserved  |

Remark: Dialing operation cannot be performed unless the power supply is cut off.

### 5-3 Parameter check instructions

#### 1) Historical error code query

1. Press 'CHECK\_A' or 'CHECK\_B' button to item 60, this is the recent error code:

2. Long press 'COOL' button for 3s, enter historical fault query.

Press 'CHECK\_A' or 'CHECK\_B' to switch the fault number, 'N1.' indicates the second to last fault; 'N2.' indicates the third last fault, and so on. 'N63.' is the last fault, up to 64 historical faults can be stored, and historical faults can be saved even after power failure.

After entering the fault record query, if without any operation within 20s, it automatically returns back to the frequency display or standby display.

#### 2) Parameter setting at project site

1. In normal display state, long press 'COOL' button for 3s, enter parameter setting function: SHx is displayed ('x' means number), short press 'COOL' button to switch the parameter items, such as from SH1-> SH2-> SH3...

2. Each parameter item can be changed by pressing 'CHECK\_A' or 'CHECK\_B' button. After setting parameter, there is no operation within 10s, the setting will be saved automatically. After 20s without any operations, it will automatically return to the frequency display or standby display.

**SH1:** Cooling T2B target value A (unit: °C, range: 5-15), the factory default is 8°C;

**SH2:** Heating T2 target value B (unit: °C, range: 40-50), the factory default is 44°C;

**SH3:** Power saving mode value C (range: 40-100), it means that the outdoor unit can output 40%, 50%, 60%, 70%, 80%, 90%, 100%, and the factory default is 100%;

**SH4:** Auto charging refrigerant function (range: 0&1), the factory default is 0, there is no auto charging refrigerant function, SV10 valve is always closed. '1' means there is auto charging refrigerant function, SV10 valve can be turned on or off according to the relevant date judgment. This parameter will turn to '0' if powered off, that means no power off memory function.

**SH5:** The Longest defrosting period (unit: min, range: 5-20), the factory default is 10 minutes.

**SH6:** Exit defrost temperature T3 value, (unit: °C, range: 10-18), the factory default is 15°C;

**SH7:** Allow indoor unit offline time value, (unit: min, range: 60-480), you can choose from 8 values of 60, 120, 180, 240, 300, 360, 420, 480. The factory default is 60 minutes;

**SH8:** Allow indoor unit offline quantity value, (unit: pcs, range: 0-6), the factory default is 2;

**SH9:** Reserved.

# 5. Electrical wiring

## 3) Forced cooling

- Short Press 'COOL' button to enter forced cooling.
- The 1<sup>st</sup> time press is forced cooling, 'dH' is displayed.
- The 2<sup>nd</sup> time press is to exit forced cooling to standby state.
- The 3<sup>th</sup> time press is forced cooling, and so on.
- Forced cooling will automatically exit after 1 hour.

## 5-4 Terminal functions

See Fig.5.1 and Fig.5.2.

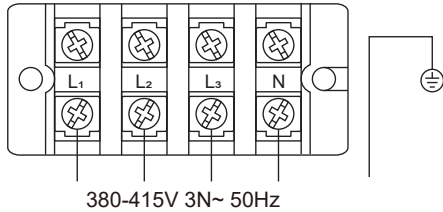

Fig. 5.1 Power supply terminal

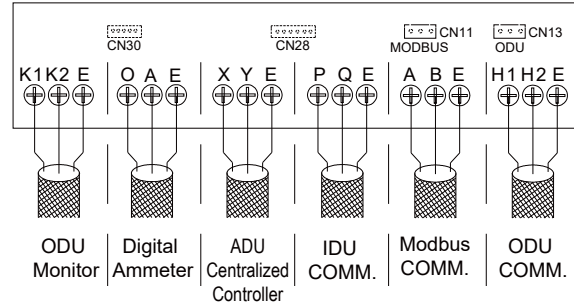

Fig. 5.2 Communication terminal

## 5-5 Electrical system and installation

### 1) Precautions in electrical wiring

- The power supplies for indoor unit and outdoor units shall be separately designed.
- The power supply must be designed with special branch circuit, and equipped with current leakage protector and manual switch.
- Power supply, current leakage protector and manual switch connected to the same outdoor unit must be with the versatility. (The indoor unit power supply in the same system must be in the same circuit and switched on or off at the same time, or the system service life may be shortened and the machine may fail in starting up.)
- The indoor and outdoor connecting and wiring system shall be included in the same system with the refrigerant tube system.
- To reduce the interference, the indoor and outdoor signal line shall be the 2-core shielded cable other than unshielded multi-core cable.
- Electrical wiring shall be performed according to national related standards.
- Electrical wiring must be done by a professional electrician. Supply cords of parts of appliances for outdoor use shall not be lighter than polychloroprene sheathed flexible cord (code designation 60245 IEC 57).
- The indoor unit and outdoor unit must have a reliable grounding wire.

### 2) Power supply cable for outdoor unit

- Power cable diameter and air circuit selection.

Tab.5.4 Power supply cable for outdoor unit

| Item Type | Power supply | Recommended cable diameter (mm²)(<20mm) | Manual switch(A) | Current leakage protector |
|-----------|--------------|---|------------------|---------------------------|
|           |              |   | Capacity         |                           |
| 8HP       | 380V3N~50Hz  | 6.0×5                                   | 32               | 100mA<0.1sec              |
| 10HP      | 380V3N~50Hz  | 6.0×5                                   | 32               |                           |
| 12HP      | 380V3N~50Hz  | 6.0×5                                   | 32               |                           |
| 14HP      | 380V3N~50Hz  | 10.0×5                                  | 50               |                           |
| 16HP      | 380V3N~50Hz  | 10.0×5                                  | 50               |                           |
| 18HP      | 380V3N~50Hz  | 16.0×5                                  | 63               |                           |
| 20HP      | 380V3N~50Hz  | 16.0×5                                  | 63               |                           |
| 22HP      | 380V3N~50Hz  | 16.0×5                                  | 63               |                           |
| 24HP      | 380V3N~50Hz  | 16.0×5                                  | 63               |                           |
| 26HP      | 380V3N~50Hz  | 16.0×5                                  | 63               |                           |
| 28HP      | 380V3N~50Hz  | 16.0×5                                  | 63               |                           |
| 30HP      | 380V3N~50Hz  | 25.0×6                                  | 80               |                           |
| 32HP      | 380V3N~50Hz  | 25.0×5                                  | 80               |                           |

# 5. Electrical wiring

**NOTICE**

1. Each unit has a separate power supply, so the electrical wiring for each unit shall comply with the corresponding standard.(Tab.5.4)
2. The diameter and continuous length of cables in the table is for the situation when the voltage drop is within 2%, and the cable diameter shall be selected as per the related specification if the continuous length goes beyond the value in the table.

2. Outdoor unit power wiring

○ Correct Mode

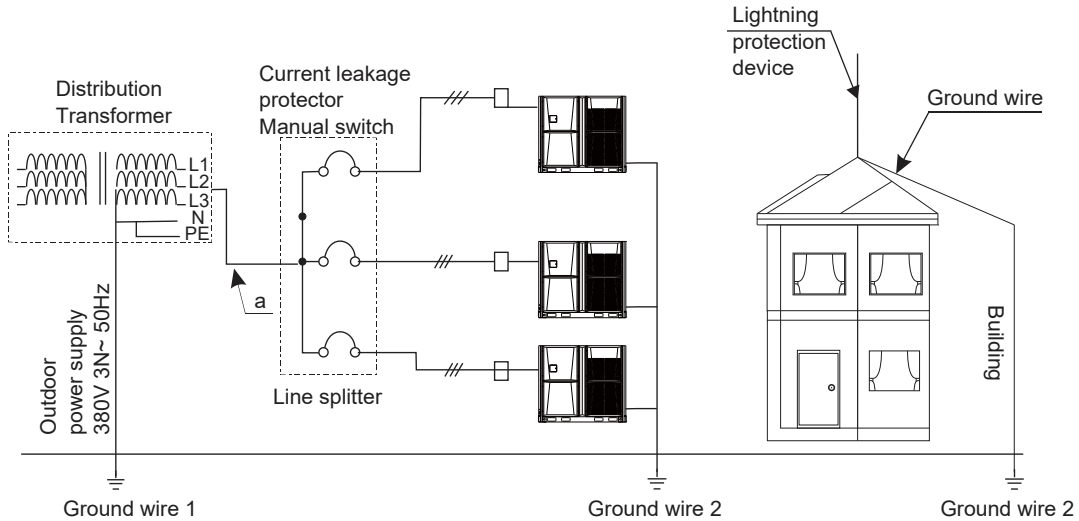

Fig. 5.3 Power supply device 1

✗ Incorrect Mode

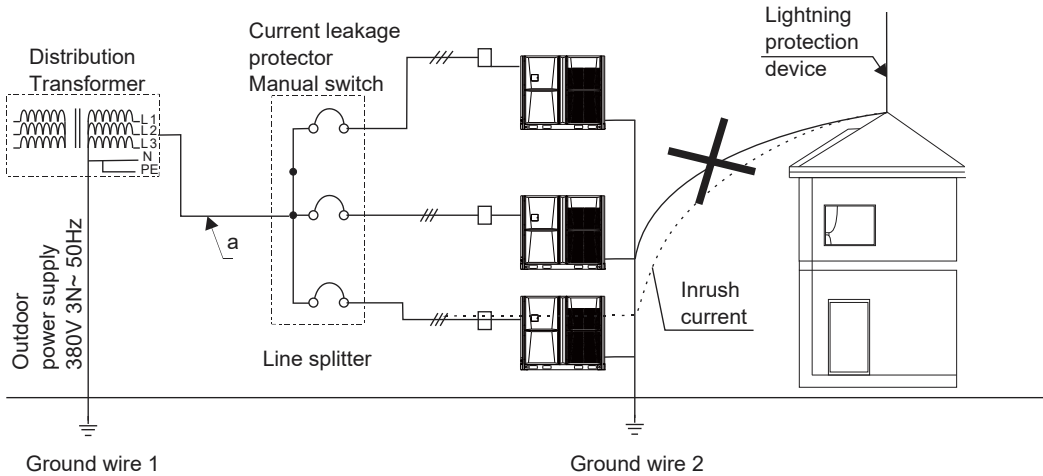

Fig. 5.4 Power supply device 2

**NOTICE**

1. It is forbidden to connect the ground wire of the lightning protection device to the machine casing. The ground wire of the lightning protection device must be configured separately from the power supply ground wire.

# 5. Electrical wiring

## 3) Cable of power supply for indoor unit

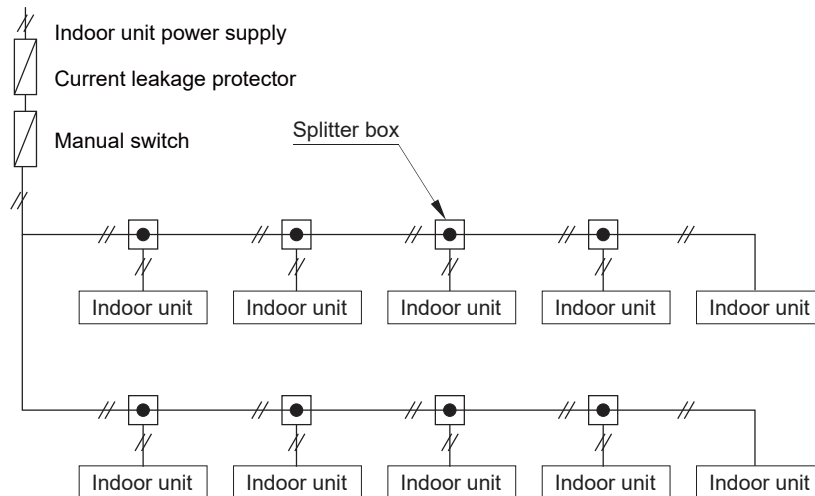

Fig. 5.5 Indoor unit power supply

### ! NOTICE

1. The refrigerant tube system, indoor unit indoor unit, and indoor unit outdoor unit connecting and signal lines are designed in the same system.
2. All indoor units of a same system must be fed by the uniform power supply.
3. When the power supply line is parallel with the signal line, they must be isolated by cable chutes and spaced in an enough distance. (Power supply line space: 300mm for 10A below, 500mm for 50A below)
4. When multiple outdoor units are parallel connected, the addresses for outdoor units must be correctly set.

## 5-6 Signal cable between indoor and outdoor units

1) 2-core shielded cable ( $\geq 0.75\text{mm}^2$ ) shall be used for the signal cable between indoor and outdoor units, the cable must be connected in correct polarities, and the signal cable between the indoor and outdoor units can be only led out from the master outdoor unit.

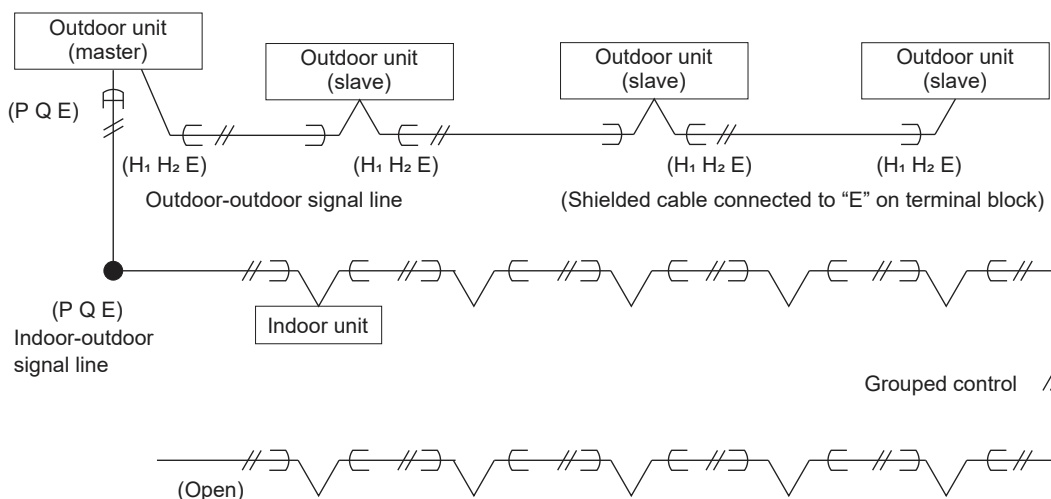

Fig. 5.6 Signal cable between indoor and outdoor units

### Remark:

Please add a 100Ω or 120Ω resistance between P and Q terminal of the last indoor unit when it is needed (The communication is not stable or too many indoor units in one system).



# 5. Electrical wiring

## 5-7 Example for electrical wiring (Power supply 380-415V 3N~ 50Hz)

See Fig.5.7.

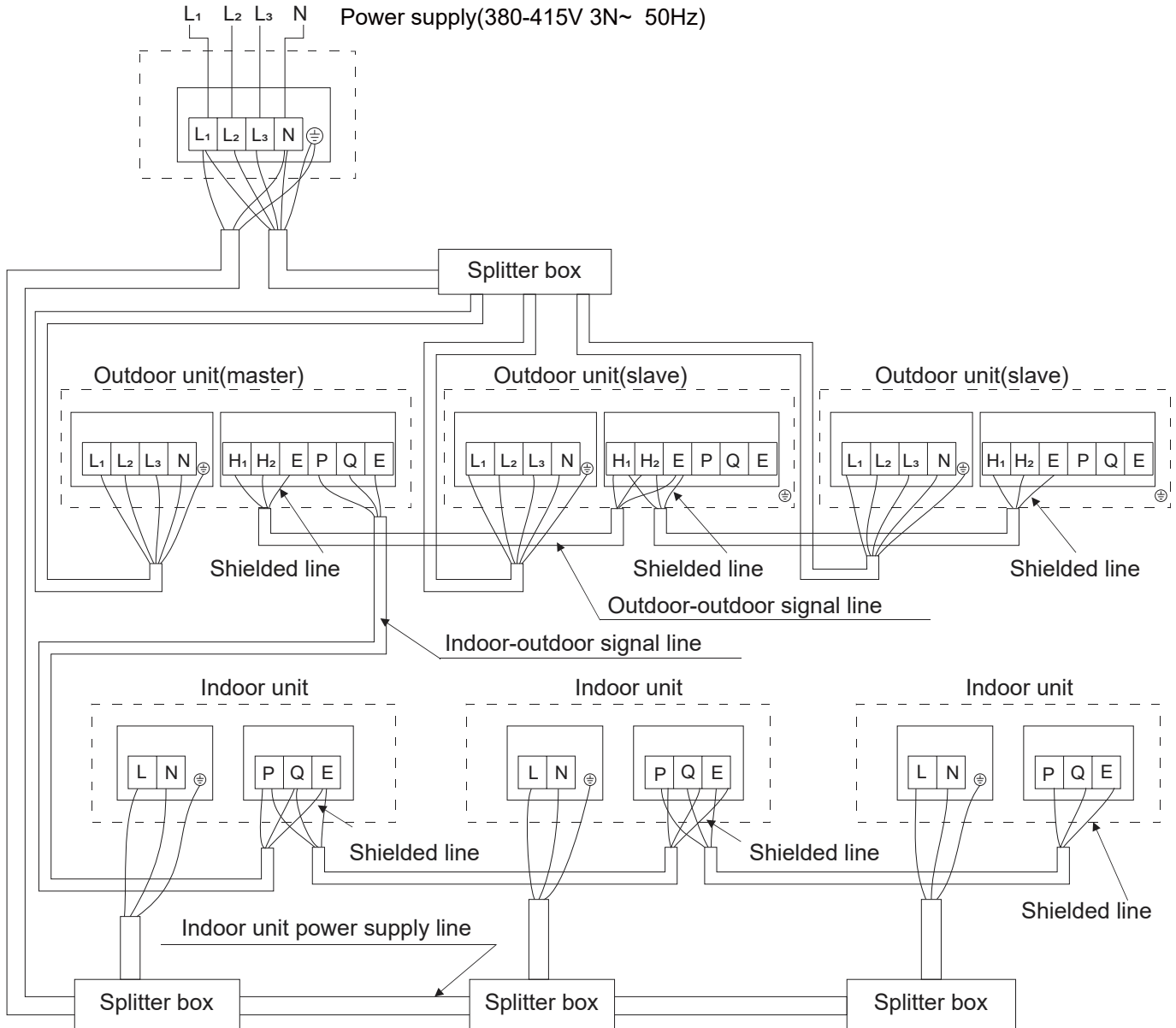

Fig. 5.7 Example for electrical wiring

Remark:

1. When all the indoor part power consumption is too big, this connection method is not available;
2. When the 3 phase power supply is not stable, this connection method is not allowed;
3. In case of this problem as above, please power indoor and outdoor part individually.

## 6. Trial running

### 6-1 Inspection and confirmation before debugging

- 1) Check and make sure the refrigerating pipeline and communication line between the indoor and outdoor units are in the same refrigerating system, or some operation fault may occur.
- 2) The voltage power supply is within  $\pm 10\%$  of the rated voltage.
- 3) Check and make sure the power supply line and control line are correctly connected.
- 4) Make sure there is not short circuit before the system is electrified.
- 5) Make sure all units have passed the 24h nitrogen pressure maintaining test (4.0MPa).
- 6) Make sure the system is fully vacuumized, dried and filled with the refrigerant as per the specification.

### 6-2 Preparation before debugging

- 1) Calculate the amount of refrigerant to be refilled as per the field liquid tube length.
- 2) Prepare the required refrigerant.
- 3) Prepare the system planar drawing, system pipeline drawing and control line drawing.
- 4) Record the well set address codes on the system planar drawing.
- 5) Turn on the outdoor unit power supply switch in advance, and make sure it is connected for more than 12h to make the heater heating the compressor oil.
- 6) Fully open the outdoor unit gas tube check valve, liquid tube check valve and oil balance valve, or the machine may be damaged.
- 7) Check if the phase sequence of the outdoor unit power supply is correct.
- 8) Check if all dialing switches of the outdoor and indoor units are set as per the product technical requirement.

### 6-3 Name filling of connected systems

When setting several indoor units, each connecting system of the indoor unit and outdoor units shall be identified and named and recorded on the nameplate of outdoor unit electrical control box cover.

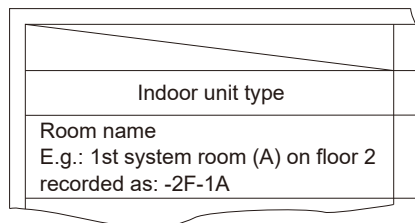

Fig. 6.1 Name filling of connected systems

### 6-4 Precautions against refrigerant leakage

- 1) The refrigerant itself of this air conditioner is harmless, nonflammable and safe.
- 2) The air conditioner room shall be of a suitable space size so that the refrigerant concentration will not go beyond the limit even if leakage happens, and some necessary measures can be taken additionally.
- 3) The critical gas concentration harmless for the human body is  $0.3\text{kg/m}^3$ .
- 4) Confirm the critical concentration as per the following steps and take necessary measures correspondingly.
  1. Calculate the full volume of refrigerant to be filled (A[kg])  
Full refrigerant volume = refrigerant volume at delivery (see the nameplate) + refrigerant volume to be refilled for the corresponding tube length.
  2. Calculate the indoor cubage (B[m<sup>3</sup>]) (as per the minimum cubage)
  3. Calculate the refrigerant concentration

$$\frac{A[\text{kg}]}{B[\text{m}^3]} \leq \text{critical concentration: } 0.3[\text{kg/m}^3].$$

## 6. Trial running

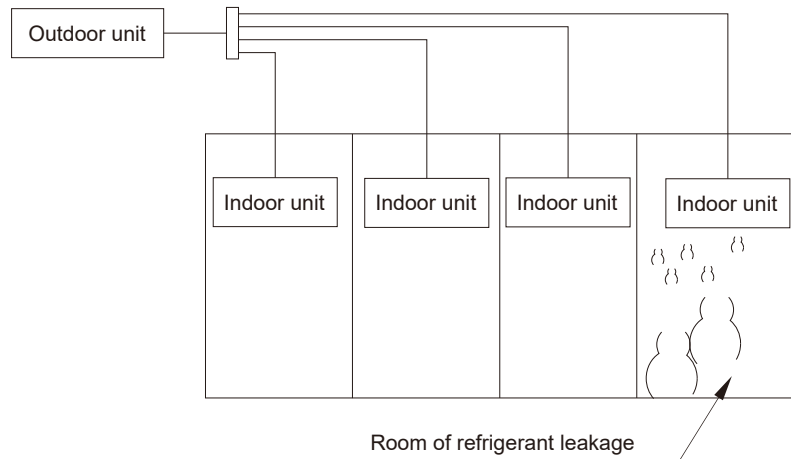

Fig. 6.2 Refrigerant leakage

### 5) Measures against exceeding the critical concentration

1. To control the refrigerant concentration below the critical concentration, a mechanical air ventilating device shall be installed (for frequent air ventilating).
2. If frequent air ventilating cannot be realized, please install a leakage warning and detecting apparatus interlinked with the mechanical air ventilating device.
3. The leakage warning and detecting apparatus shall be installed in a place with dense refrigerant accumulation.

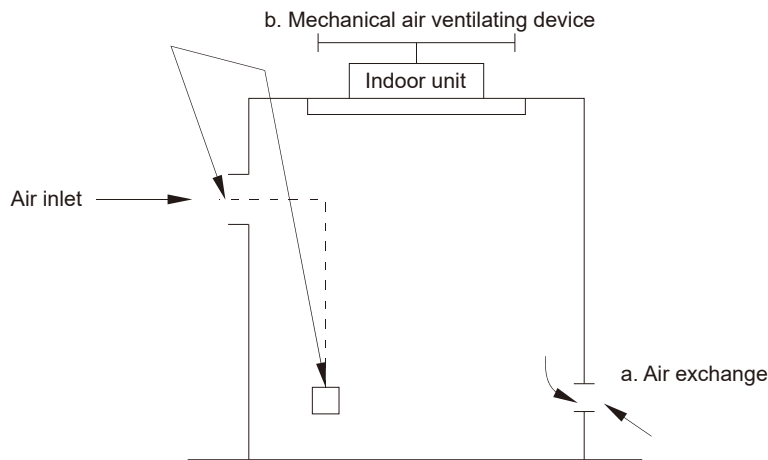

Fig. 6.3 Air exchange

### 6-5 Hand over to the client

1. The Instruction Manual for the indoor unit, Instruction Manual for the outdoor unit and Direction for Customer Service must be submitted to the client.
2. Explain the content of Instruction Manual to the client carefully.

### 6-6 Correct Disposal of this product



This marking indicates that this product should not be disposed with other household wastes throughout the EU. To prevent possible harm to the environment or human health from uncontrolled waste disposal, recycle it responsibly to promote the sustainable reuse of material resources. To return your used device, please use the return and collection systems or contact the retailer where the product was purchased. They can take this product for environmental safe recycling.

# **INSTALLATION MANUAL**

Original instructions

SA-ZM33ENG-8

802000190340